

Grey Cloud Slough Restoration

Feasibility Study



DRAFT

May 8, 2012



Prepared by:



DRAFT

CERTIFICATION

South Washington Watershed District

Grey Cloud Slough Restoration Feasibility Study

I hereby certify that this plan, specification, or report, was prepared by me or under my direct supervision, and that I am a duly Registered Professional Engineer under the laws of the State of Minnesota.

Mark R. Deutschman, P.E.

Minn. Reg. No. 42303

Mike Lawrence, P.E.

Minn. Reg. No. 49191

Date: May 8, 2012



Houston Engineering, Inc.
6901 East Fish Lake Road, Suite 140
Maple Grove, Minnesota 55369
763.493.4522 (Phone)
763.493.5572 (Fax)
www.houstoneng.com

HEI Project No. R114876-015

DRAFT

Table of Contents

1	Introduction	1
1.1	Historical Context.....	1
1.2	Geotechnical Background Information.....	2
1.3	Roadway Geometry	3
2	Project Goals and Design Criteria	5
2.1	Project Goals	5
2.2	Design Criteria.....	5
3	Range of Alternatives Considered.....	9
3.1	No-Action Alternative	9
3.2	Small Culvert Alternative	9
3.3	Large Culvert Alternative	9
3.4	Bridge Alternative	10
4	Methods.....	11
4.1	Survey Data Collection	11
4.2	Hydrology.....	11
4.3	Hydraulics.....	14
4.3.1	Model Development	14
4.3.2	Boundary Conditions.....	18
4.3.3	Amount of Flow Through Meander From Mississippi River (Flow Split)	18
4.3.4	Water Surface Profiles	19
4.4	Fish Passage	22
4.5	Geomorphology and Sediment Transport	23
4.6	Water Quality.....	27
4.6.1	Hydraulic Residence Time Analysis.....	28
4.6.2	HEC-RAS Water Quality Simulation.....	30
4.7	Navigability.....	33
5	Analysis of Alternatives.....	35
5.1	Small Culvert Alternative	36
5.2	Large Culvert Alternative	38
5.3	Bridge Alternative	40
6	Environmental Impacts and Permitting	47

DRAFT

6.1	Permitting	47
6.1.1	Federal	47
6.1.2	State	47
6.1.3	Local	47
6.1.4	Summary	47
6.2	COE Mississippi River Operational Considerations	48
7	Project Feasibility and Engineer’s Recommendation	49
7.1	Project Feasibility	49
7.2	Engineer’s Recommendation	49
8	References	51
9	List of Appendices	52
9.1	Appendix A: Braun Intertec Preliminary Geotechnical Assessment	52
9.2	Appendix B: Soil Boring Logs	52
9.3	Appendix C: HEC-RAS Results	52
9.4	Appendix D: Sediment Transport Results	52

List of Figures

Figure 1: Project Location.	4
Figure 2: Design Vessel Diagram with Terms.	8
Figure 3: HEC-RAS Model Extents for the Mississippi River.	15
Figure 4: Location of Grey Cloud Channel Model Cross Sections.	16
Figure 5: Water Surface Profiles for Range of Alternatives– 2 year Flood Event.	20
Figure 6: Water Surface Profiles for Range of Alternatives – 10 year Flood Event	21
Figure 7: Water Surface Profiles for Range of Alternatives– 100 year Flood Event	21
Figure 8: Critical Water Velocities for Fish Passage Design.	22
Figure 9: Bed Gradation Curve for Sediment Transport Analysis.	25
Figure 10: Sediment Transport Results Channel Invert Change April through September	27
Figure 11: HEC-RAS Water Quality Results Graph of Chlorophyll-a Concentrations.	33
Figure 12: Preliminary Engineering Drawing for the Small Culvert Alternative.	43
Figure 13: Preliminary Engineering Drawing for the Large Culvert Alternative.	44
Figure 14: Preliminary Engineering Drawing for the Bridge Alternative.	45
Figure 15: Photograph and Schematic of Pre-Cast Bottomless Culvert.	46

DRAFT

List of Tables

Table 1: Mississippi River Return Period Discharges Derived from Annual Maximum Series.....	12
Table 2: Percentile Flows for Mississippi River May through September.	13
Table 3: Percentile Flows for Mississippi River Entire Year.	13
Table 4: Average Monthly Flows for Mississippi River.....	13
Table 5: Datum Conversions.	14
Table 6: HECRAS Model Verification of 100 Year Flows.	17
Table 7: Downstream Boundary Condition, Lock and Dam Number 2 Rating Curve.	18
Table 8: Estimated Proportion of Total Mississippi River Flow Entering Grey Cloud Slough Meander by Alternative.	19
Table 9: Critical Flows for Walleye Passage	23
Table 10: Sediment Transport Inputs Used in the HEC-RAS Model.....	25
Table 11: Sediment Load (TSS) Grain Size Distribution.....	26
Table 12: Sediment Transport Results Loading Summary April through September	26
Table 13: Existing Estimated Hydraulic Residence Times for the Mississippi River and Mooer’s Lake	29
Table 14: Grey Cloud Slough Estimated Hydraulic Residence Time Rating Curve.....	29
Table 15: Water Quality Data Stations Utilized in the HEC-RAS Model.....	31
Table 16: Water Quality Data Used for the Initial Conditions and Boundary Condition at the Inlet to the Meander.....	31
Table 17: HEC-RAS Water Quality Model Input Values and Rate Coefficients.	32
Table 18: Navigability Vertical Clearances for Large Culvert and Bridge Alternatives.	34
Table 19: Alternative Analysis Matrix.	35
Table 20: Preliminary Opinion of Probable Construction Cost for the Small Culvert Alternative.	37
Table 21: Preliminary Opinion of Probable Construction Cost for the Large Culvert Alternative.	39
Table 22: Preliminary Opinion of Probable Construction Cost for the Bridge Alternative.	42

1 Introduction

The Grey Cloud Island Slough is located east of the main channel of the Mississippi River, near the boundary between Grey Cloud Township and St. Paul Park, Washington County, Minnesota and within the south-east portion of the Minneapolis – St. Paul metropolitan area. Although coined a “slough” this 2.8 mile long waterbody is a “cut-off” meander loop of the Mississippi River. The mouth of this meander begins at Mississippi River Mile (RM) 827.6 and ends at the confluence of a larger backwater portion of the Mississippi River immediately north of Grey Cloud Island. Grey Cloud Island Drive South crosses the meander an estimated 1,800 feet downstream from the mouth. Although within the backwater area downstream of the confluence with the meander, two other roads potentially influence the flow of water through the meander. Grey Cloud Island Drive South also crosses the backwater area as well as Grey Cloud Trail South.

Restoration of the ecological functions and services historically provided by the Grey Cloud Island Slough as a meander of the Mississippi River is a priority for many local, state, and federal agencies. Some of these agencies include the U.S. Army Corps of Engineers (COE), the National Park Service (NPS), the U.S. Fish and Wildlife Service (FWS), the Minnesota Department of Natural Resources (DNR), Washington County, Grey Cloud Township and the South Washington Watershed District (SWWD). Washington County and Grey Cloud Island Township have an additional interest as the transportation entity responsible for Grey Cloud Island Drive South.

1.1 Historical Context

Ecological functions and services provided by the meander are diminished, in part because of the loss of longitudinal connectivity with the Mississippi River. Water can no longer flow through the meander. Longitudinal connectivity within a flowing system like the meander is necessary to provide suitable fish spawning and rearing, to allow for the unimpeded movement of fish and aquatic organisms, to ensure “normal” sediment transport and biogeochemical processes, and to avoid degraded water quality. Longitudinal connectivity has diminished through time because of reduced flow through the meander, first because of the replacement of a bridge by a culvert, with the subsequent complete loss of culvert function.

Mr. Rich Mullen the Grey Cloud Township Clerk provided the following oral history. Historically, a wooden bridge crossed Grey Cloud Slough. The initial construction date of this bridge is unknown, but likely occurred early in the 1900’s. In 1923, plans were developed to replace the bridge with culverts and fill over the culverts across the meander channel. The project was constructed in the same year, although the exact size and type of the culverts placed at the time is unknown. The U.S. Army Corps of Engineers (COE) constructed Lock and Dam Number 2 near Hastings, MN in 1930. The lock and dam went into service in July of 1931. The culvert crossing functioned with little or no problems until the flood of 1965. As flood water rose during that year an emergency road raise was undertaken. The exact height of additional fill placed to raise the road at that time is unknown, but it was at this time the existing culverts under the road were filled over as the road was raised. The highest peak flow in the general vicinity of the meander mouth on the Mississippi River occurred on April 16, 1965 at an estimated 171,000 cubic feet per second (cfs). No flow is believed to have occurred through those

DRAFT

culverts since the road raise took place in April of 1965. The second largest flood of record on the Mississippi River in the vicinity of the meander occurred only four years later on April 15, 1969 with an estimated flow of 156,000 cfs. There was approximately 3' of elevation difference between the top of the road and the water level (i.e., freeboard) during this flood according to Mr. Mullen.

The lack of longitudinal connectivity because of the lack of flow through the culverts resulting from the emergency road raise has caused the water quality and the general ecological condition within the meander to degrade over time. The need to maintain meander ecological functions and services were not considered when the decision was originally made to replace the bridge with culverts, nor the decision to raise the road. The current water quality issues caused by the loss of connectivity can easily be seen in **Figure 1** by the large algae bloom present in the channel.

The SWWD Board of Managers is providing local leadership for this project by completing a feasibility study for restoring the ecological functions and services to the Grey Cloud Island Slough. The SWWD formed a Technical Advisory Committee (TAC) in April 2011 for the project. The TAC is comprised of representatives from the COE, National Park Service (NPS), U.S. Fish and Wildlife Service (FWS), Minnesota Department of Natural Resources (DNR), Grey Cloud Island Township, Washington County and the SWWD. While the TAC supported the concept of restoring the meander during early meetings, they also raised a number of technical issues. Those issues included the need for a formal feasibility study to identify a preferred alternative to reestablish longitudinal connectivity, whether the crossing design should allow for the passage of recreational boating traffic. In June, 2011 the SWWD Board of Managers approved issuing bonds to provide funding for the restoration of the Grey Cloud Slough. These funds are dedicated to completing the feasibility study¹ and construction of a “feasible” restoration alternative. The SWWD Board of Managers retained Houston Engineering, Inc. (HEI) to complete the feasibility study.

1.2 Geotechnical Background Information

The current road embankment across Grey Cloud Slough is known to have water moving through it during large flood events, most recently in the spring of 2011. Braun Intertec completed a preliminary analysis of the stability of the current road embankment (see **Appendix A**). In March of 2011, Braun Intertec under contract to Washington County, drilled four penetration test borings in the vicinity of the former bridge. Those borings were denoted ST-1, ST-2, ST-3, and ST-4.

Braun Intertec noted that below the existing pavement, the borings encountered mixed but generally sandy fill to depths that, in the vicinity of the proposed bridge (i.e., the current culvert location) (Borings ST-2 and ST-3), ranged from approximately 14 to 31 feet. The uniformity and consistency of the fill varied widely. At Boring ST-3, in particular, their hollow stem auger dropped between depths of approximately 6 and 14 feet, suggesting the presence of a large void or a series of voids in the fill at that location. Penetration resistance values as low as 1 blow per foot were also recorded in debris-laden

¹ Although the project has been the subject of several University of Minnesota student Capstone projects, the District and the TAC believed a more formal feasibility study was necessary.

DRAFT

(mainly wood) portions of the fill and in some cases the weight of the sampling hammer alone was sufficient to cause 1 foot of penetration.

Braun Intertec also reported the fill is underlain with alluvial soils consisting mainly of sand but, at Boring ST-3, with organic silt as well. The alluvial soils were generally very loose to loose. The alluvial soils continued to the 21 foot termination depth of Boring ST-2, but were penetrated by Boring ST-3 at about the 40-foot depth, below which very dense material judged to be glacial outwash or weathered limestone bedrock was encountered.

The boring logs described above can be found in **Appendix B**. Based on the current borings and the description above, there is a large degree of uncertainty in the makeup of the road embankment relative to its structural integrity. Particularly troubling is the large void that was found in the road. Regardless of the alternative selected as a part of this project, additional geotechnical analysis is needed. The means of addressing the uncertainty in this feasibility study is through the rather large contingency applied to the Preliminary Opinion of Probable Construction Cost (POPCC).

1.3 Roadway Geometry

The current horizontal and vertical alignment of Grey Cloud Drive South contains very tight curves and limited sight line distances. The current speed limit on the roadway is 45 miles per hour (mph) with an advisory speed² of 30 mph. Heading from east to west along the road over the crossing the road elevation changes by approximately 50 feet along a horizontal curve with an approximate radius of 246-feet. The calculated design speed for this curve is 27 mph. Continuing west along the road over the crossing the road elevation increases approximately 40 feet along a horizontal curve with an approximate radius of 229'. The calculated design speed for this curve is 25 mph. Both curves have a super-elevation of 4%. These calculated design speeds are based on table 3-2.03A of the MNDOT Road Design Manual, Dec 2004, minimum radius formula for rural roads, using friction factor of 0.160. Neither of these curves meets the current posted advisory speed of 30 mph. The County has stated that the existing vertical and horizontal alignments of Grey Cloud Drive are adequate and no change is necessary. The existing roadway alignments were used when preparing the preliminary plans and POPCC as part of this study.

² An advisory speed limit is a speed limit that is recommended by the governing road authority, but is not enforced. These advisory speeds are posted with yellow signs as opposed to white for speed limit signs.

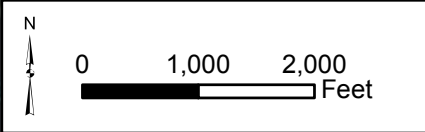
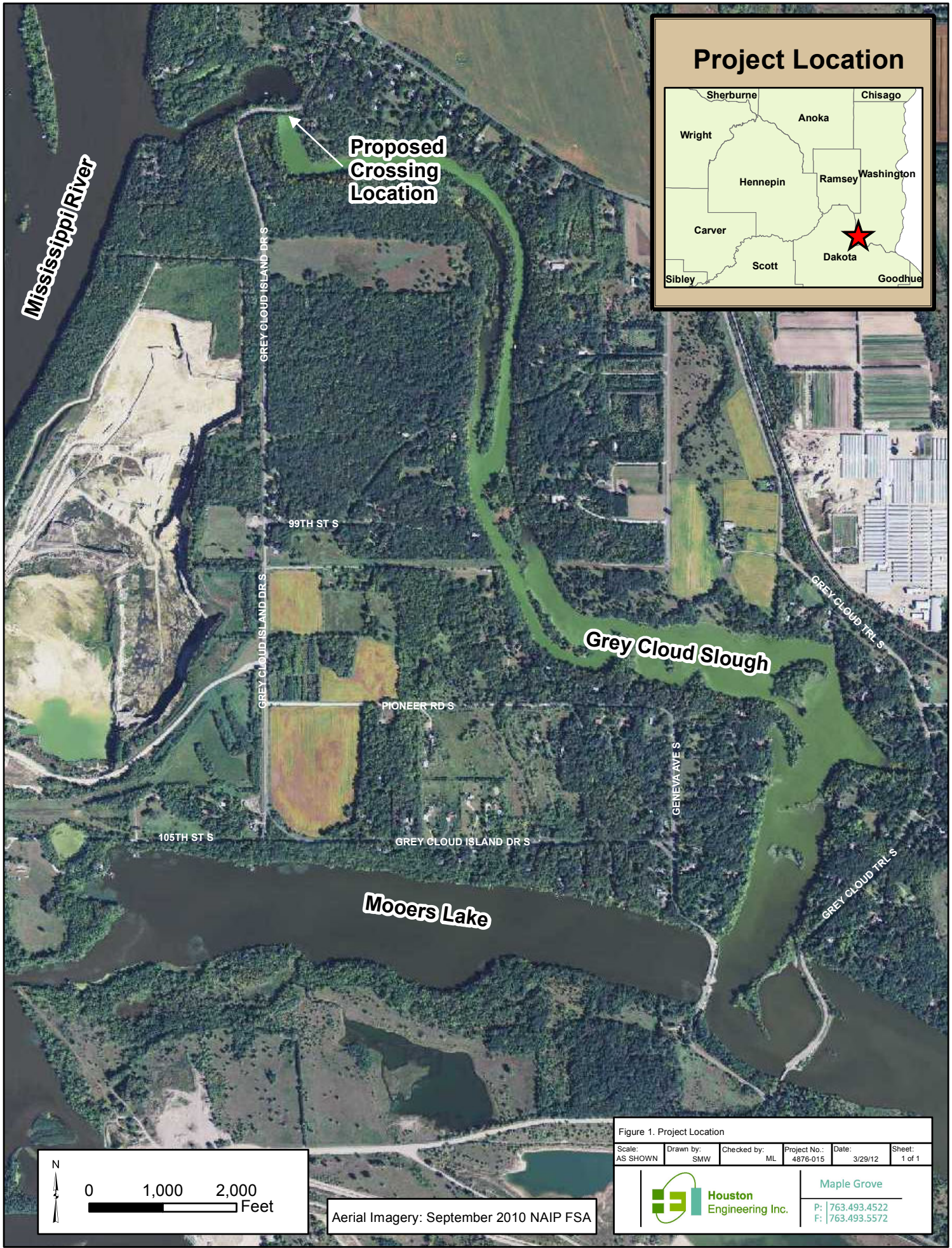

Aerial Imagery: September 2010 NAIP FSA

Figure 1. Project Location

Scale: AS SHOWN	Drawn by: SMW	Checked by: ML	Project No.: 4876-015	Date: 3/29/12	Sheet: 1 of 1
--------------------	------------------	-------------------	--------------------------	------------------	------------------

 Houston Engineering Inc.	Maple Grove
	P: 763.493.4522 F: 763.493.5572

2 Project Goals and Design Criteria

2.1 Project Goals

The primary goal is to restore the ecological functions and services provided by the meander to a condition more reflective of a “natural” system by reestablishing longitudinal connectivity. A more natural condition is defined as at a minimum, the conveyance, flow, and hydraulic conditions, which existed prior to the installation of the current culverts³ assuming proper function. Additional secondary goals are related to the level of service for the transportation system and recreational boating. These goals include no overtopping of Grey Cloud Island Drive South for the 1% chance flood event and the ability to allow the passage of recreational sized (small boat) watercraft up to a maximum length of 20-feet (specific design criteria for each of these goals follows in **Section 2.2**). Achieving the primary goals is mandatory for an alternative to be considered feasible. Achieving the secondary goals is not considered mandatory for an alternative to be considered feasible. Whether a goal is mandatory is subject to discussion of and resolution within the TAC and may be related to availability of outside funding for the construction of the restoration project.

2.2 Design Criteria

The design criteria are categorized according to the type of goal. The expectation is that an alternative which incorporates the design criteria will achieve that goal. Recognizing that different design criteria can control the final dimensions of the culvert or bridge structure is important. For example, the design criteria for restoration of the ecological functions and services may result in one set of dimensions for the structure, but the criteria for the passage of recreational watercraft may require considerably different dimensions.

Restoration of Ecological Functions and Services

Longitudinal and Lateral Ecological Connectivity

Hydrologic criteria are used to assess the longitudinal and lateral ecological connectivity of the meander, as an indicator of energy flow, nutrient processing, biogeochemical pathways, and similar ecological processes. The hydrologic criteria used to assess longitudinal and lateral connectivity include:

- Prefer uninhibited conveyance (i.e., limited change in water surface elevation across the road crossing) for the 50% chance (2-year) and 10% chance (10-year) flood events (longitudinal transfer of energy downstream);
- Prefer more “uniform” width of the area inundated by the 10% chance flood event from the source of the meander to the mouth (lateral connectivity for energy transfer to / from riparian area); and

³ Restoration of the “majority” of the historic ecological functions and services of the meander is expected by creating conveyance, flow, and hydraulic conditions similar to the condition that existed with a bridge, fully recognizing that this condition is not the historic ecological function and services provided by the meander in the absence of a crossing.

DRAFT

- Relative change in the estimated water levels (minimum, median (normal), and maximum). The minimum and maximum water levels are a measure of the amount of ecological disturbance related to hydrology and necessary for “resetting” ecological processes.

Passage of Fish and other Aquatic Species

The design criteria for the passage of fish and aquatic species are provided fully recognizing the presence of zebra mussels and other Aquatic Invasive Species (AIS) within the Mississippi River. The current road crossing prevents the movement of these species through the meander. Because the meander is connected to the Mississippi River, the presence of AIS through the entire meander even in the absence of providing passage is probable. The passage of fish and other aquatic species design criteria include:

- A mean velocity through the structure which allows for the passage for fish species up to a 10% chance (10-year return period)⁴ discharge (i.e., mean velocity < representative species “cruising” speed);
- Presence of a roughened structure substrate to provide a refugia to fish during high velocity flows (allowing periodic higher velocities through structure – use of species burst speed);
- A change in abrupt grade less than the jumping height for indicator fish species (e.g., bass); and
- A normal water elevation depth > 1-foot (using 2-year return period event) as a minimum depth requirement.

Sediment Transport and Waterway Geomorphic Stability

These criteria are used to assess the ability of the meander to convey sediment and to assess sediment deposition patterns, compared to the current condition and reasonably ensure the stability of the meander bed and banks. The criteria are expected to provide guidance in determining areas of sediment scour and deposition and a relative indication of channel stability. The design criteria include:

- Non-erosive velocity at bank toe and meander bed for:
 - Dominant discharge
 - Use 2-year flood event as indicator of dominant discharge⁵
- Sediment transport capacity (mass per unit width)
 - Dominant discharge
 - Use 2-year flood event as indicator of dominant discharge
- Sediment deposition patterns
 - Relative comparison of scour and deposition patterns for a range of discharges

⁴ The 10 year return period criteria was modified slightly to relate the passage to a critical flow, this is discussed in detail in Section 4.4.

⁵ The indicator discharge subsequently changed in the analysis to a mean monthly discharge from May through September.

DRAFT

Water Quality

Water quality criteria are used to assess the relative change in water quality for an alternative compared to the current condition and the condition on the Mississippi River. The design criteria used to evaluate alternatives and assess water quality include:

- The amount of nutrients expressed as the concentration of total phosphorus and algae expressed as the chlorophyll-a concentration;
- Water quality (expressed in terms of nutrient concentrations) relative to upstream (Mississippi River) and downstream (Mississippi River backwater) boundary conditions; and
- Relative change in hydraulic residence time / flushing rate.

Transportation

The transportation design criteria pertain to the anticipated traffic level of service, ensuring a safe transportation system with geometry based on current design standards and the likelihood of the road / structure overtopping. The specific transportation design criteria include:

Level of Service

- Provide at a minimum, the current level of service

Safety

- Geometric design consistent with posted speeds

Frequency of Overtopping and Flood Characteristics

- Consistent with Minnesota DOT Risk Analysis requirements
- No overtopping for the 1% flood event

Recreational Boating

The design criteria for recreational boating are used to describe the type of recreational watercraft able to pass through the road crossing for the normal water depth⁶. These criteria may result in a larger or smaller crossing size than based on the transportation design criterion (or other design criteria). Terms used in the description of the criteria are shown in **Figure 2**.

Design Vessel

- Propeller boat maximum length range 16-feet to 21-feet
- Maximum height 6-feet
- Beam width 8-feet
- Draft 2-feet

⁶ The design criteria used for this feasibility study differ from those recommended by the DNR. This is discussed in greater detail in Section 4.7.

DRAFT

- Squat 0.5-feet
- Vertical safety clearance 3-feet
- Horizontal safety clearance 2-feet on each side of beam width

Design Event

- Normal water level resulting from median summer flow: 686.66 NAVD88.

Figure 2: Design Vessel Diagram with Terms.

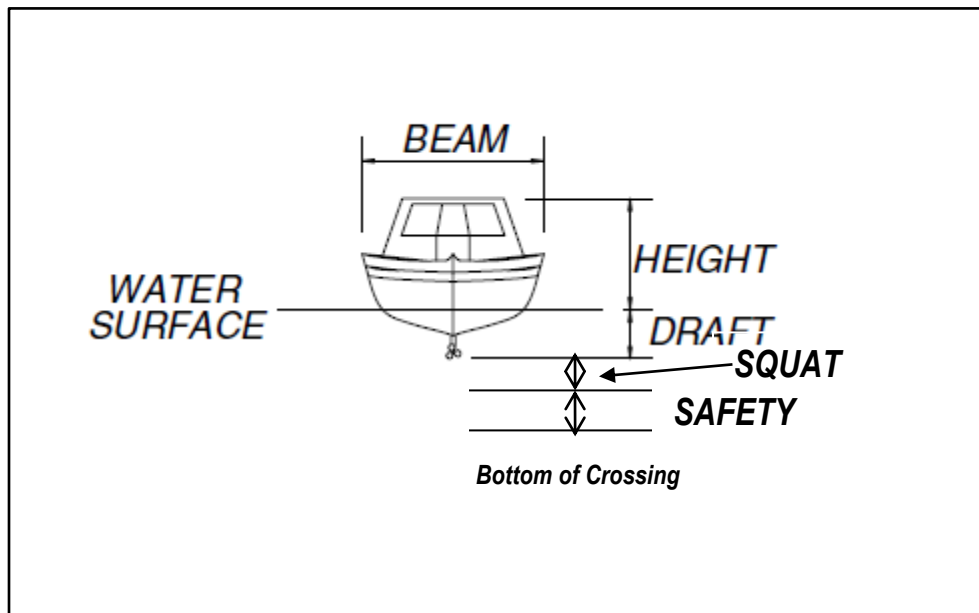

3 Range of Alternatives Considered

The feasibility study evaluated a range of potential alternatives to restore the meander and the TAC assisted in prioritizing the alternatives evaluated within the feasibility study. Following concurrence from the TAC relative to the design criteria, several preliminary crossing alternatives were evaluated for their performance. The TAC reviewed the preliminary performance information and selected the alternatives subjected to a more detailed analysis (which is described in **Section 4**). Four preliminary alternatives were considered by the TAC.

3.1 No-Action Alternative

The first alternative is the No Action Alternative. The Grey Cloud Island Drive crossing has been in nearly the same condition since 1965. In its current condition water quality within the meander is poor and native aquatic plants vigor and fish abundance has seemingly decreased over time. Given the fact the channel has had similar hydrology over the last fifty years it is likely that conditions in the channel will change very little in the future for the No Action Alternative. Conditions will neither improve nor further degrade. There is of course no immediate cost associated with this alternative. However, the stability of the roadway embankment will continue to be an issue and likely degrade over time and at some time the current corrugated metal pipe culverts will collapse. This alternative requires no further analysis, as it does not result in a solution to the problem.

3.2 Small Culvert Alternative

The Small Culvert Alternative consists of installing a culvert under the roadway to achieve only the water quality goal. (For example, there would be no consideration of recreational boating.) A preliminary size for a small culvert (essentially the minimum size) was determined by the water quality analysis performed in this report (see **Section 4.6**). Preliminary analysis showed the size of the culvert necessary to meet the water quality goals is an 8' wide by 6' high reinforced concrete box culvert. Other types and shapes of culverts were considered, such as corrugated metal pipe and circular reinforced concrete culverts. However, reinforced concrete box culverts provide the greatest longevity of the two types and also the easiest placement over circular culverts especially for the larger sizes.

3.3 Large Culvert Alternative

The Large Culvert Alternative consists of installing a large box culvert under the roadway which meets both the water quality and recreational boating goals. The TAC recommended the culvert opening width and height be increased as much as possible, to allow for the passage of recreational boats. In addition, the TAC also suggested the culvert length be as short as possible to minimize the amount of fill necessary to reconstruct the roadway embankment.

The largest standard MNDOT box culvert currently available is 16' high by 16' wide. Slightly larger culverts are available, but due to shipping limitations these culverts have much higher cost and a general lack of availability. Therefore, the TAC recommended analyzing a 16' x 16' reinforced concrete box culvert as the Large Culvert Alternative. Other material types and shapes were reviewed, such as a structural plate circular or arch pipe. The circular or arch culverts are not as easily navigable due to the fact that the full height of the culvert is present for only a small portion of the span.

DRAFT

The length of the culvert is a function of roadway width and roadway side slopes. In order to shorten the culvert as much as possible, the roadway width needs to be as narrow as possible and the side slopes as steep as permissible while ensuring slope stability, and meeting highway safety standards. Guardrails were chosen as the means to shorten the culvert length thereby allowing for the use of steeper side slopes in the clear zone⁷.

3.4 Bridge Alternative

The final alternative considered is the Bridge Alternative. Constructing a bridge at the site is expected to be somewhat challenging due to the complex roadway geometry and the uncertainty associated with the geotechnical stability and unknown nature of the current embankment. While there are many possible types of bridges that could be constructed, most bridges constructed on similar roadways are pre-stressed concrete beam bridges and concrete slab span bridges. The advantages of a pre-stressed concrete beam bridge are the ability to span up to 150 feet, simple design and construction, speed of construction, and durability. The disadvantages are the depth of structure and the shipping limitations that may limit the use of longer beams.

Concrete slab span bridges can attain a 50 foot middle span when three or more spans are used. The concrete slab span provides the absolute minimum structure depth of all bridge types and is typically an economical solution. The slab span is also considered slightly more aesthetic for smaller stream crossings. The disadvantages of the slab span are the requirements for formwork support and the limits on span length.

The costs for the two bridge types are very similar when looking at a cost per square foot basis. In recent years the concrete slab span has been slightly cheaper by about 5%, according to the MNDOT State Aid Bridge Office's 2011 Bridge Cost Report. Because the structure depth will play a key role in how much of a road raise is required and subsequently the total cost of the project, the concrete slab span was selected as the bridge type for this alternative.

An option as a part of this alternative is a "bottomless culvert". This is a pre-cast structure that is placed on footings and fill is placed over the structure. The appearance and construction would be similar to a bridge, except that no bridge deck will be present (i.e. the regular paved roadway is placed over the top). The absence of the bridge deck may be more favorable to some stakeholders.

⁷ The clear zone for a roadway is the total road way border area which is available for safe use by an errant vehicle.

4 Methods

4.1 Survey Data Collection

Survey data were collected by Houston Engineering, Inc. during late October of 2011. Cross sections were surveyed approximately every 1000' along the entire length of the meander. Measurements of the channel bottom elevation along the longitudinal profile were surveyed at approximately every 150' along the entire channel length. Survey data were collected using a modern Trimble R6 Global Position System (GPS) which recorded the horizontal position of each measured water depth (relative to the water surface at the time of the survey). The edge of the water surface was surveyed along the entire channel. These surveyed elevations showed a flat water surface profile. Therefore, all of the water surface elevations were averaged and used to convert the water depth measurements to an elevation. Elevations at the top of the channel bank were also collected.

Road centerline and edge of road locations and elevations were collected along 2400' of the road through the site. The roadway data were collected using a modern Trimble 5600 robotic total station using set control from GPS. For all the surveying and modeling completed, the horizontal datum is Washington County North American Datum 1983 (NAD83) with a linear unit of feet and the vertical datum is the North American Vertical Datum of 1988 (NAVD88) in feet. Because the original hydraulic model of the Mississippi River was not created as a part of this project, the topography data used for that portion of the model is discussed in **Section 4.3**. All elevations referenced in this report are NAVD88, unless otherwise noted.

4.2 Hydrology

This section presents the hydrologic data used to analyze the range of alternatives. All of the hydrologic analyses completed are based upon measured streamflow (i.e., discharge) at USGS Gage 0533100, Mississippi River at St. Paul MN. This gage record dates from 1892 to present. Discharges for various return periods were obtained from the Washington County, MN Flood Insurance Study dated February 3, 2010. The Flood Insurance Study states the flows were obtained from the 1979 U.S. Army Corps of Engineer's Flow Frequency Study. The 1979 study used a HEC-FFA (flood frequency analysis) of the gage record to determine the peak discharges. A flood frequency analysis is the determination of flood flows at different return periods (i.e. the 1% chance of occurrence in any given year, also known as the "100 year return period"). Flood frequency analyses are used to determine how often on average a certain discharge is expected to occur. For this study, the data of interest are the annual maximum discharges on the Mississippi River. The peak discharges used for this study are shown in **Table 1**. There is a flow change location along the study reach (i.e. the computed flows increase due to the increased drainage area). This occurs at Mississippi River Mile 824, which is approximately 3.5 miles downstream from the inlet to Grey Cloud Slough.

DRAFT

Percentile rankings of the mean daily discharges of the USGS gage were also performed. This ranking used all available years for the gage, but only used flows from May through September. The May through September time period was selected because the water quality problems and recreational boating are most prevalent during that time. The results from this analysis are shown in **Table 2**. The 50th percentile discharge (i.e. median) and 5th percentile discharge were used in hydraulic analysis, which is discussed in detail in **Section 4.3**. The 50th percentile discharge was also used in the water quality analysis, which is discussed in **Section 4.6**. A similar percentile ranking of discharges for the gage was performed, using the data for all months of the year. These results are shown in **Table 3** and were used when analyzing the fish passage capabilities of the proposed crossing.

Average monthly flows for the gage were also computed and are shown in **Table 4**. These averages provide a general indication of the timing of flows in the system. These monthly averages were used in the sediment transport analysis in **Section 4.5**.

Table 1: Mississippi River Return Period Discharges Derived from Annual Maximum Series.

Mississippi River at St. Paul, MN			Mississippi River at River Mile 824 (Flow change at RAS station 74386)		
Return Period (yr)	Percent Annual Chance	Peak Discharge (cfs)	Return Period (yr)	Percent Annual Chance	Peak Discharge (cfs)
2	50	38,500*	2	50	38,500*
5	5	64,000	5	5	64,000
10	10	83,000	10	10	84,000
50	2	130,000	50	2	131,000
100	1	150,000	100	1	151,000
500	0.2	203,000	500	0.2	205,000

Source: 2010 Washington County FIS

*Taken from Table B-7 in 2003 USACE Flow Frequency Study⁸

⁸ In 2003, the COE completed another Flow Frequency Study to update the 1979 study. However, the 1979 flows were adopted for the 2003 study. The 2 year return period discharge was not completed in the 1979 study, so the 2003 flow frequency study flow was used for the 2 year return period. It should be noted that when the 2003 Flow Frequency Study was reviewed there were discrepancies found between discharges in tables and some figures, the discharge from the table was used.

DRAFT

Table 2: Percentile Flows for Mississippi River May through September.

USGS Gage 0533100 Mississippi River at St. Paul, MN May through September Discharge (1892-2011)	
Percentile	Mean Daily Discharge (cfs)
0.1	796
1	1,300
5	2,620
25	5,580
50	10,300
75	19,600
95	41,400
99	58,800
99.9	87,421

Table 3: Percentile Flows for Mississippi River Entire Year.

USGS Gage 0533100 Mississippi River at St. Paul, MN Entire Year Discharge (1892-2011)	
Percentile	Mean Daily Discharge (cfs)
0.1	870
1	1,309
5	2,090
25	4,300
50	7,440
75	15,000
95	38,800
99	60,810
99.9	124,000

Table 4: Average Monthly Flows for Mississippi River.

Average Monthly Flow (cfs) (1892-2011)											
Jan	Feb	Mar	Apr	May	Jun	Jul	Aug	Sep	Oct	Nov	Dec
4,770	4,710	11,500	26,900	21,700	18,900	14,600	8,870	8,140	8,810	8,110	5,870

Flows from USGS 05331000 Mississippi River at St. Paul, MN

4.3 Hydraulics

This section of the feasibility study describes the methods used to complete the hydraulic analyses including a description of model development and use for analyzing the range of alternatives.

4.3.1 Model Development

The Hydraulic Engineering Center’s River Analysis System (HEC-RAS) model, version 4.1.0, was selected for use in this analysis. The model geometry is a combination of an existing hydraulic model of the Mississippi River and a newly created geometry for the Grey Cloud Slough Channel as surveyed by Houston Engineering, Inc. The HEC-RAS model is the successor to the COE HEC-2 model.

A HEC-2 model is the current effective FIS model for the Mississippi river. This HEC-2 model was originally created from information in a 1972 Minnesota DNR report. The model was eventually modified to include flood control projects in St. Paul and is in datum NGVD 29. The COE in St. Paul subsequently took the HEC-2 model and converted the model to HEC-RAS as well as to datum NAVD88. The COE modified the cross section geometry for the overbank areas based upon recent 2-foot topography acquired for the area. The COE used this updated HEC-RAS model to assess levees in the St. Paul area during the high flows experienced in 2011. HEI used this COE converted HEC-RAS model as the base model for the analysis on Grey Cloud Slough. While the vertical datum conversion was completed by others, the datum conversions are shown in **Table 5**.

Table 5: Datum Conversions.

MSL 1912 - 0.48' = NGVD 1929
NGVD 1929 + 0.15' = NAVD 1988

HEC-geoRAS, a GIS software tool, was used to help develop the geometric data in the hydraulic model for Grey Cloud Slough reach. The software utilized both the surveyed cross section data and overbank data from 2-foot contours created by SWWD using Washington County’s DTM from their 2009 orthophoto project. This reach for the meander was then inserted into the larger Mississippi River HEC-RAS model from the COE. The overall model extents and cross section layout are shown in **Figure 3**. The model originally included two junctions where a reach representing Mooers Lake was connected to the Mississippi River. With the addition of the Grey Cloud Slough meander into the model, two additional junctions were created. The cross section layout and stationing for the Grey Cloud Slough is shown in **Figure 4**. These cross section stations are referenced throughout **Section 4** for the various analyses.

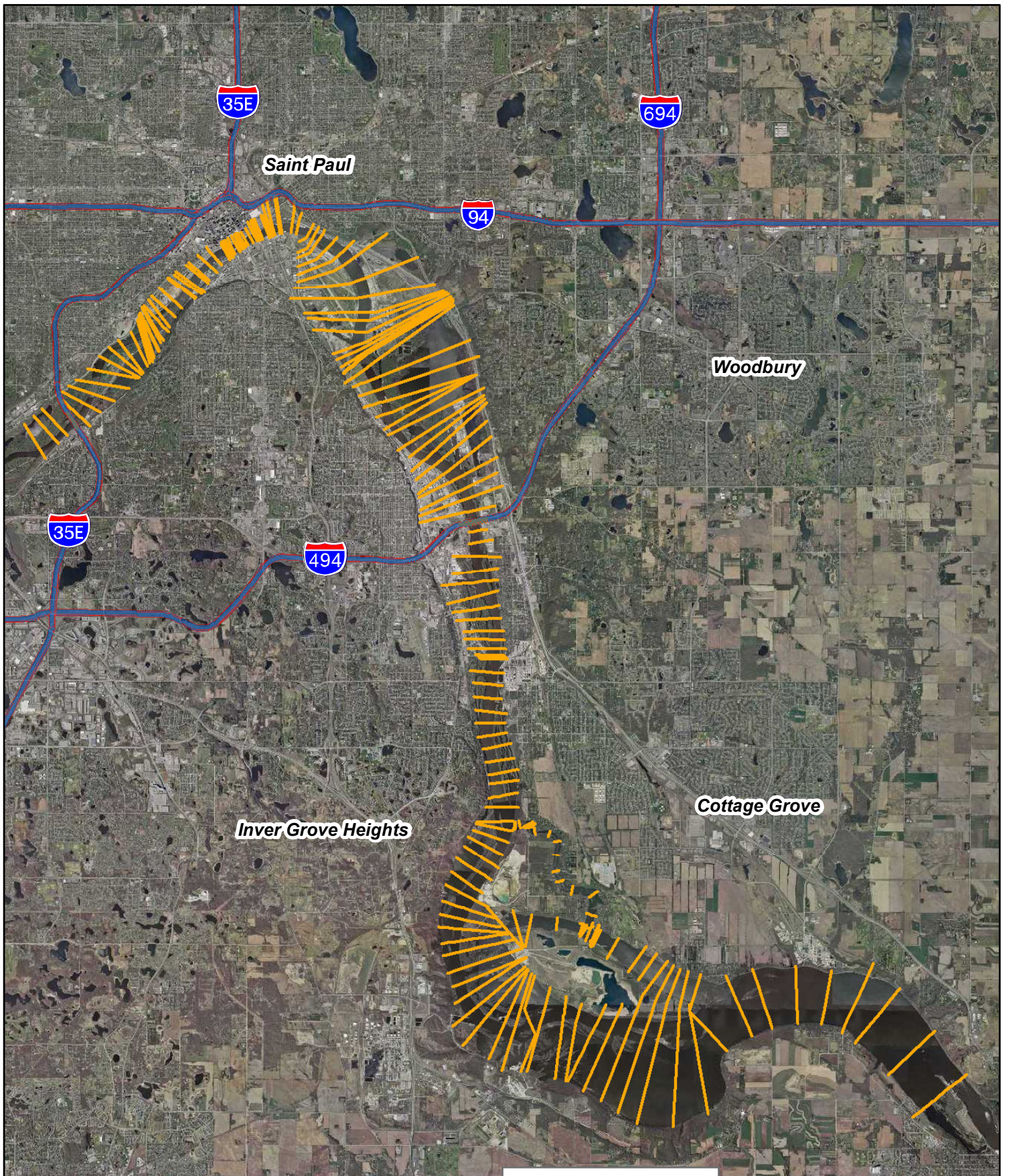



Figure 3. HEC-RAS Model Extents

Scale: AS SHOWN	Drawn by: SMW	Checked by: ML	Project No.: 4876-015	Date: 3/29/12	Sheet: 1 of 1
--------------------	------------------	-------------------	--------------------------	------------------	------------------

 Houston Engineering Inc.	Maple Grove
	P: 763.493.4522
	F: 763.493.5572

— HEC-RAS Cross Sections

0 0.75 1.5 3 Miles



Hastings

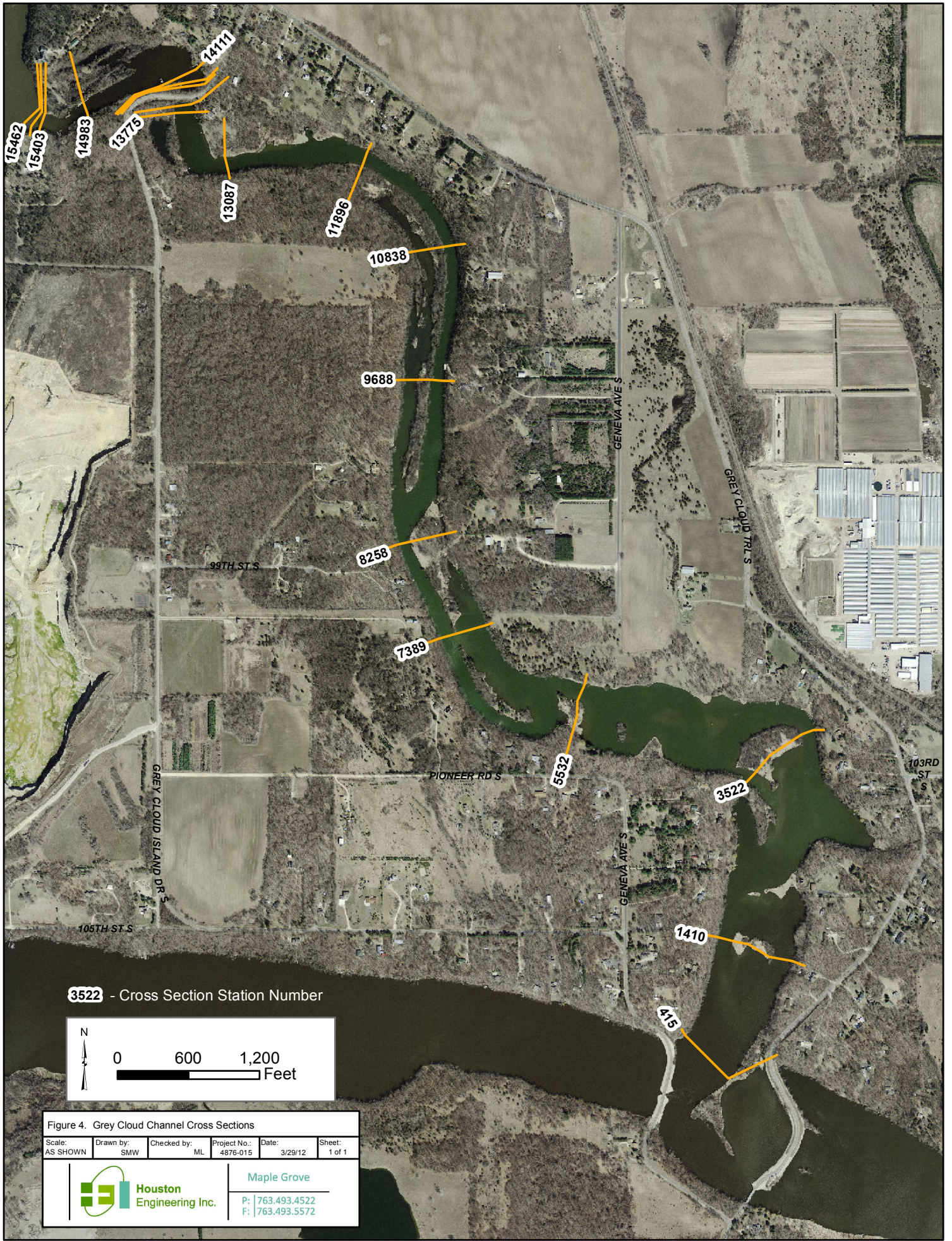

3522 - Cross Section Station Number

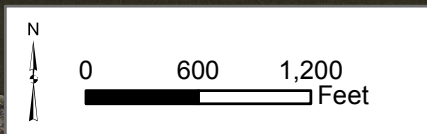



Figure 4. Grey Cloud Channel Cross Sections

Scale: AS SHOWN	Drawn by: SMW	Checked by: ML	Project No.: 4876-015	Date: 3/29/12	Sheet: 1 of 1
--------------------	------------------	-------------------	--------------------------	------------------	------------------

 Houston Engineering Inc.	Maple Grove
	P: 763.493.4522 F: 763.493.5572

DRAFT

The original HEC-2 model was calibrated, but with the conversion to HEC-RAS and modifications to overbank areas a verification of the new model was necessary. The HEC-RAS model was compared to elevations in the original HEC-2 model by HEI and was found to be reasonable. The results are shown in **Table 6**. The largest differences were approximately half a foot around the Grey Cloud Channel inlet. These differences can be attributed to an increase in elevation in the overbank in this area. No effort was made to match results to the HEC-2 model, due to the fact that the modifications in the overbank areas most likely represent an improvement in model geometry because of the use of more recent detailed topographic data. This analysis was simply a verification. Based on this verification, the current HEC-RAS model adequately portrays the Mississippi River and Mooers Lake compared to previous hydraulic modeling efforts and can be used for this feasibility study.

Table 6: HECRAS Model Verification of 100 Year Flows.

Flood Insurance Study		HEI HEC-RAS Model		Elevation Difference (ft)	Location
Cross Section ID	Modeled Water Surface Elevation (NAVD88 ft)	Cross Section ID	Modeled Water Surface Elevation (NAVD 88 ft)		
Mississippi River					
AQ	700.1	95531.88	700.52	0.42	Grey Cloud Channel Inlet
AN	699.5	92343.52	699.99	0.49	
AM	699.3	91620.46	699.86	0.56	
AJ	698.9	88595.44	699.13	0.23	
AG	698.5	85335.97	698.66	0.16	
AF	698	80475.75	698.2	0.2	Mooers Lake Channel Inlet
AD	697.8	77978.84	697.99	0.19	
U	697.2	66497.47	697.42	0.22	
Q	697.1	60970.84	697.25	0.15	
M	696.8	54807.92	696.99	0.19	Mooers Lake Channel Outlet
L	696.6	51073.71	696.72	0.12	
Mooers Lake					
G	698.2	19926.23	698.45	0.25	
E	698.2	15609.23	698.42	0.22	
D	696.8	10632.91	696.95	0.15	
B	696.8	5703.883	696.93	0.13	
A	696.8	4068.945	696.93	0.13	

DRAFT

4.3.2 Boundary Conditions

The downstream boundary condition for the HECRAS model is Lock and Dam Number 2 on the Mississippi River. This boundary condition is modeled as a rating curve on the most downstream cross section. The rating curve was obtained from the Army Corps of Engineers St. Paul District and is shown in **Table 7**.

Table 7: Downstream Boundary Condition, Lock and Dam Number 2 Rating Curve.

Elevation (NAVD88)	Flow (cfs)
686.87	0
686.79	3,000
686.77	4,000
686.7	5,000
686.67	6,000
686.59	7,000
686.52	8,000
686.45	9,000
686.37	10,000
686.27	11,000
686.17	12,000
686.17	...
686.17	61,000
686.2	62,500
686.27	64,000
686.48	66,000
686.99	70,000
688.21	80,000
689.33	90,000
690.4	100,000
691.48	110,000
692.54	120,000
693.57	130,000
694.47	140,000
695.32	150,000
696.12	160,000
696.87	170,000
697.57	180,000
700.6	225,000
705	300,000
710.3	400,000
715	500,000

4.3.3 Amount of Flow Through Meander From Mississippi River (Flow Split)

While the HEC-RAS model was used for a variety of analyses and comparisons, one of the most important uses is to estimate the proportion of the flow from the Mississippi River entering the meander for the various alternatives (i.e., flow split). The flow splits were computed by running the HEC-RAS model assuming steady state conditions (i.e., constant flow) and selecting the flow optimization for junctions. The model iterates until a solution is reached where the head loss (i.e. change in water surface elevation) is equal across the junction. Due to the flat water surface at lower flows because of the presence of Lock and Dam Number 2, the default calculation tolerance was

DRAFT

changed from 0.02' to 0.01'. This was necessary to provide accurate flow splits below 10,000 cfs. The results of the flow split analysis are shown in **Table 8**. The results show that for the small culvert alternative less than 1% of the total Mississippi River flow enters the meander. The only exception is for the 500-year event where the road is overtopped. For larger flows, the large culvert alternative and the bridge alternative result in an estimated 2% and 5% of the total flow entering the meander, respectively. Under lower flow conditions, both the large culvert option and the bridge option result in nearly the same estimated flow proportion (i.e., 2%) entering the meander from the Mississippi River.

Table 8: Estimated Proportion of Total Mississippi River Flow Entering Grey Cloud Slough Meander by Alternative.

Return Period	Miss. River Flow (cfs)	Existing		Proposed Culvert 8' x 6', Invert 683		Proposed Culvert 16'x16',Invert 680		Proposed Bridge 100', 2:1 side slopes	
		Grey Cloud Flow (cfs)	% of Total Flow	Grey Cloud Flow (cfs)	% of Total Flow	Grey Cloud Flow (cfs)	% of Total Flow	Grey Cloud Flow (cfs)	% of Total Flow
2 year	38,500	0	0.0%	301	0.8%	949	2.5%	1,608	4.2%
5 year	64,000	0	0.0%	460	0.7%	1,521	2.4%	3,261	5.1%
10 year	83,000	0	0.0%	510	0.6%	1,917	2.3%	4,701	5.7%
50 year	130,000	0	0.0%	478	0.4%	2,614	2.0%	7,778	6.0%
100 year	150,000	0	0.0%	465	0.3%	2,665	1.8%	9,204	6.1%
500 year	203,000	3,522	1.7%	3,851	1.9%	5,556	2.7%	11,238	5.5%
5th Percentile Flow	2,620	0	0.0%	19	0.7%	48	1.8%	70	2.7%
Median Summer Flow	10,300	0	0.0%	80	0.8%	230	2.2%	304	2.9%

4.3.4 Water Surface Profiles

Water surface profiles through the meander were generated for each alternative and return period discharge. The water surface profiles for all the alternatives for the 2, 10, and 100 year flood events are shown in **Figure 5** through **Figure 7**. The Grey Cloud Slough meander is shown with the downstream end of the reach (i.e. Mooers Lake) on the left and the upstream end of the reach (i.e. Mississippi River) on the right in the Figures. Tabular results for these profiles and alternatives can be found in **Appendix C**. The water surface profiles for existing conditions and the two culvert alternatives are largely defined by the elevation of the water surface of the Mississippi River upstream from the Grey Cloud Drive crossing and the elevation of Mooers Lake downstream of the Grey Cloud Drive crossing (i.e. there are essentially two flat pools of water, one above and one below the crossing). For the bridge alternative, the channel cross section provides friction due to the larger flows because the bridge is not a restriction to flow and the slope to the water surface is notable through the reach. The unimpeded water surface profile resulting from the use of a bridge provides improved longitudinal and lateral ecological connectivity compared to the culvert options.

DRAFT

For the bridge alternative, the 100 year flood elevations will increase approximately 1.5' just downstream from the crossing when compared to existing conditions. This increase will taper off to approximately a 0.3' of increase on the downstream end of Grey Cloud Slough. Increases in the 100 year flood elevation for the two culvert options are very small; 0.21' is the largest increase for the large culvert alternative. These increases can be seen in **Figure 7**. All of the increases in 100 year flood elevations take place downstream of the Grey Cloud Drive crossing. Under existing conditions there is no flow in the reach and the elevation is controlled by Mooers Lake and Lock and Dam Number 2. Once flow is introduced below Grey Cloud Drive there is an increase in the water surface elevation. The increases in 100 year flood elevations along the Grey Cloud Slough channel will not impact any inhabited structures along the reach.

There will be larger increases in water surface elevations for flows less than the 100 year. The 10-year flow (83,000 cfs) will see an increase from existing conditions ranging from 2.4' to 0.3' for the bridge alternative and 0.6' to 0.1' for the large culvert alternative.

Figure 5: Water Surface Profiles for Range of Alternatives– 2 year Flood Event.

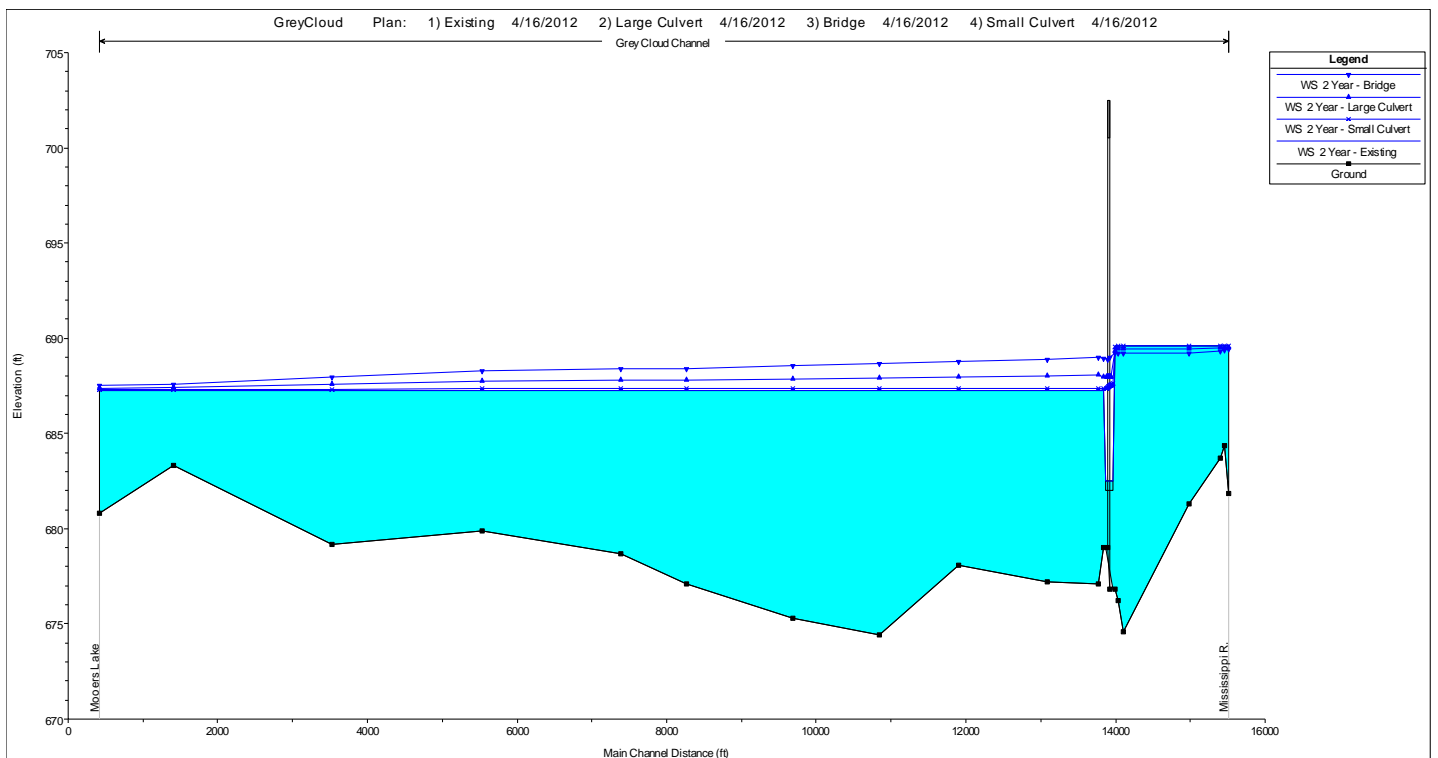

Figure 6: Water Surface Profiles for Range of Alternatives – 10 year Flood Event

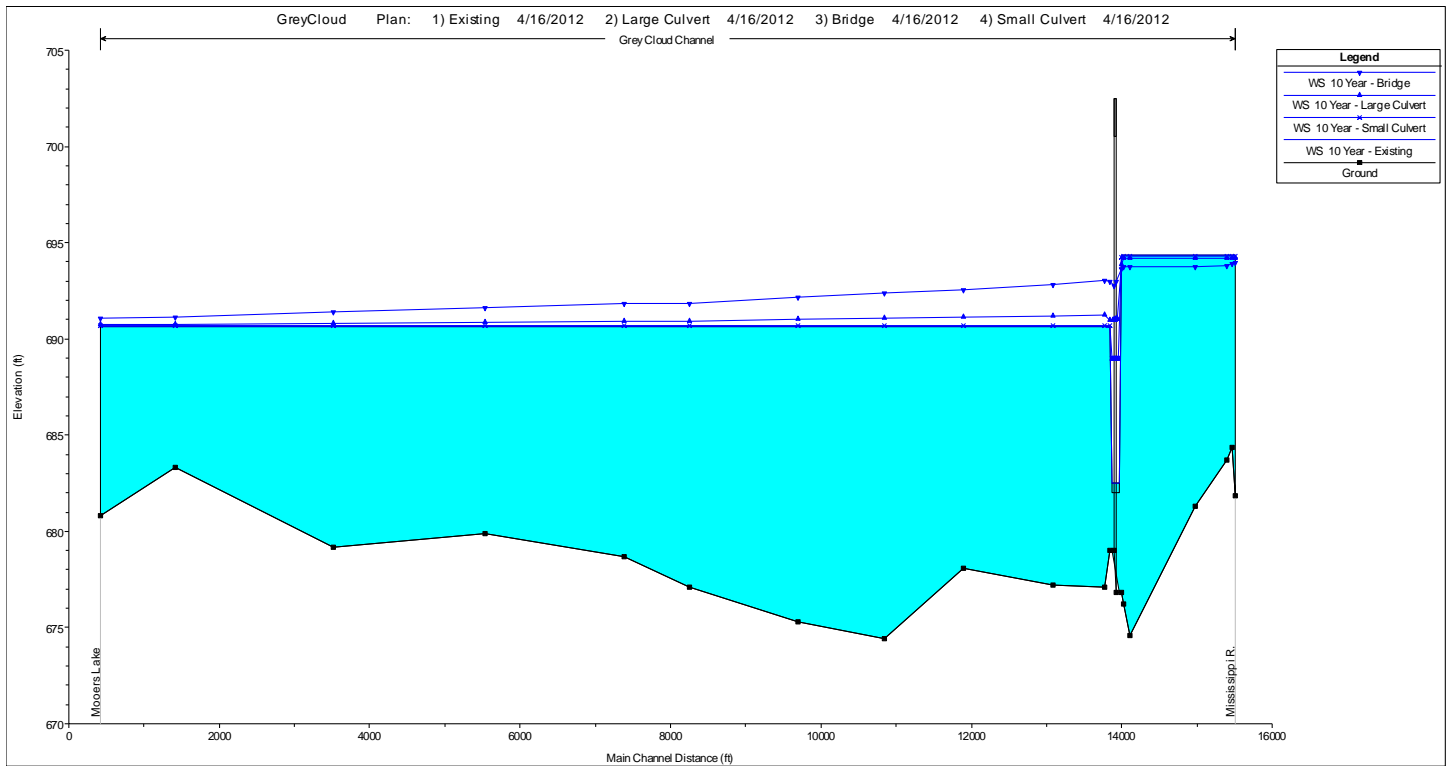
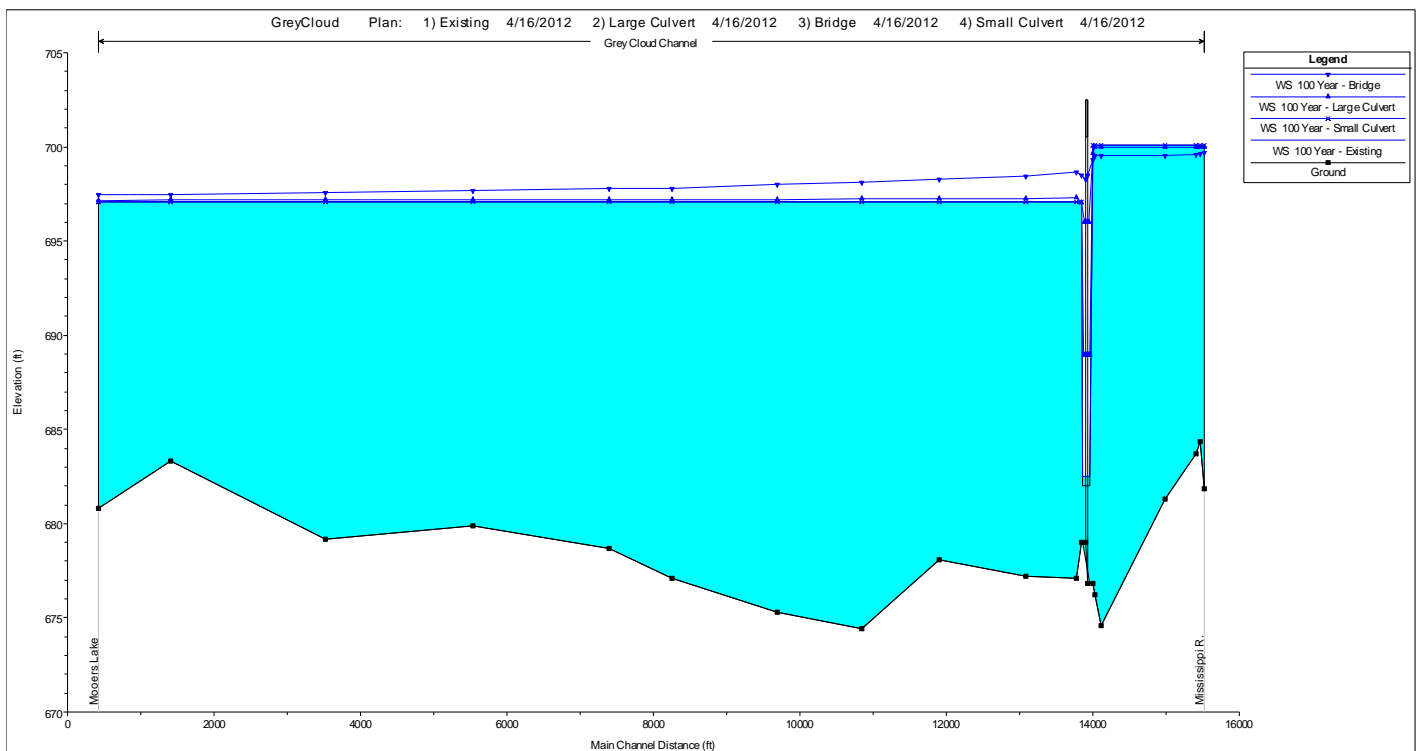

Figure 7: Water Surface Profiles for Range of Alternatives– 100 year Flood Event



4.4 Fish Passage

The ability for fish to pass through a structure is based in part upon the fish’s burst velocity, sustained swimming speed and upstream traverse distance. Critical water velocities for select species based on traverse distance are shown in **Figure 8**. For the purposes of this analysis, the walleye is used as the representative species. Additional fish species could be analyzed with the same methods if desired.

Figure 8: Critical Water Velocities for Fish Passage Design.

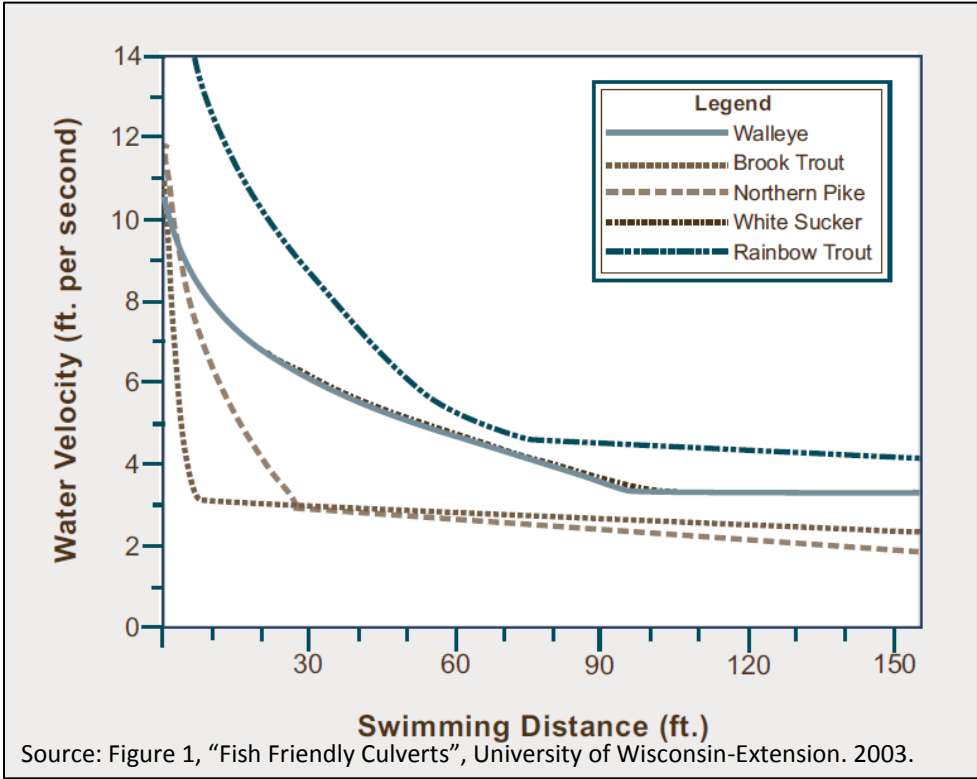

For each of the alternatives the structure length was used to determine the critical water velocity from **Figure 8**. Using the HEC-RAS model and the range of flows analyzed for each alternative, the flow in the Mississippi River that corresponds to the critical velocity in the structure was determined. The Mississippi River flow was then compared to the percentile analysis of daily flows in **Table 3** to determine the percent of the year the representative species can pass through the structure. The results from this analysis are shown in **Table 9**. It should be noted that the percent of the year the structure is passable does not take into account times of the year where fish passage may be more critical. For instance, from **Table 4**, the average April flow is 26,900 cfs. For the two culvert options, it is likely that the structures would not be passable the majority of the time in April. According to this analysis the bridge option would be passable up to a Mississippi River flow of 59,400 cfs. However, it is likely the structure would be passable for nearly all flows due to the refugia provided by the bridge piers and the riprap substrate. Based on this analysis, the bridge option provides substantially more fish passage capability unless the culvert design includes a channel bottom substrate of boulder or other materials placed to create a resting place for fish moving through the structure.

Table 9: Critical Flows for Walleye Passage

	Small Box Culvert	Large Box Culvert	Bridge
Structure Length	82'	60'	42'
Critical Water Velocity from Figure 8	4 fps	4.8 fps	5.5 fps
Corresponding Mississippi River flow	14,600 cfs	18,300 cfs	59,400 cfs
% of year with Velocity Less than Critical Water Velocity (based on daily discharge on Mississippi River)	~ 75%	~80%	~99%
Return Period of Flow	< 2 year	< 2 year	~5 year

4.5 Geomorphology and Sediment Transport

Each of the proposed alternatives needs evaluation relative to the amount of sediment which can be carried through the meander, where sediment scour and deposition may occur, and if the velocity within the meander becomes large enough to cause erosion around the crossing structural support features (i.e., piers). To develop technical data related to sediment scour and deposition (i.e., geomorphology) and sediment transport, analyses were performed using the HEC-RAS model. The data used to complete the analyses, the assumptions, and the applicable equations are discussed in this section.

The COE created a two-dimensional hydrodynamic model for the downstream half of Pool 2 of the Mississippi for the purpose of evaluating sediment transport. The model was created using the COE’s Adaptive Hydraulics model (ADH). WEST Consultants, Inc. (WEST) created the model and completed the sediment transport analysis. WEST produced the final report for the project in March of 2011 (2-D Model Report). Data, assumptions, and methodologies used in the sediment transport analysis by WEST, for the most part, were replicated in this feasibility study with some modifications. Data specifically used from this model related to the condition at the mouth of the meander and the characteristics of the sediment (i.e., upstream boundary conditions).

HEI used the “Quasi-unsteady” flow option to perform the sediment transport analysis within HEC-RAS. This consists of operating the model for a steady flow rate for a defined time period and then modifying the flow rate for subsequent time periods (i.e., a step function). For this analysis a monthly time step was selected for varying the flow rate. Flows were averaged for each month of the year using the USGS gage on the Mississippi River in St. Paul. The flows used in the analysis are shown in **Table 4**. The sediment transport model was executed for the average monthly flows for the time period of April through September.

The entire Mississippi River HEC-RAS model could not be used to simulate sediment transport, because of model limitations (i.e., HEC-RAS is unable to perform sediment transport analysis through a river junction – the junction of the mouth of Grey Cloud Island meander and the Mississippi River). Therefore, HEI separated the Grey Cloud meander from the rest of the HEC-RAS model. Because the

DRAFT

upstream boundary was changed from the Mississippi River upstream from the mouth of Grey Cloud slough to the Grey Cloud channel, results from the combined model were used to determine the flows in the Grey Cloud Channel. Flows were needed at each monthly flow level; these flows are listed in **Table 10**.

The sediment transport function in HEC-RAS also requires information about the gradation of the material comprising the bed of the river channel (i.e., bed gradation), the sediment size distribution, and sediment total load. Information about bed gradation came from the 2-D Model Report completed by WEST Consultants. HEI used the bed gradation information from river mile 827.7, which is very near the inlet to the meander. Bed gradations were available at two other locations, but this location was nearest to the Grey Cloud Channel. The size distribution of the material comprising the bed used in our analysis is shown in **Figure 9**. The curve indicates the material is nearly all sand or smaller sized materials.

The model also requires information about the total sediment load for each time step simulated, in this case each from April through September. Therefore, monthly total sediment loads were developed for use in the model. These loads were estimated using an equation with the WEST Consultants 2-D Model Report. The equation was developed using Total Suspended Solids (TSS) data at River Mile 826 from the Minnesota Pollution Control Agency. The equation is first order and relates TSS and flow in the Mississippi River. The TSS values calculated and used to compute total monthly load are presented in **Table 10**.

The final input into the model is the size distribution of the particles comprising the sediment material suspended in and transported by the water column (i.e., suspended sediment). The 2-D Model Report used a TSS particle size distribution from USGS gage 05288500 Mississippi River at Anoka, MN. The records from the Mississippi River gage at St. Paul were searched and two measurements of grain size distribution were found, compared to the eight measurements at Anoka. The two distributions were compared and found to be similar, but more fine particles were present in the St. Paul gage. The measurements from the St. Paul gage were utilized in this analysis, due to the fact that this measurement is below the confluence of the Mississippi River and the Minnesota River. The Minnesota River is a potential source of sediment to the Mississippi River upstream of the meander, so this using this location should be a more accurate representation of the TSS distribution. The distribution used in the analysis is shown in **Table 11**.

Several sediment transport equations are available in HEC-RAS. The Laursen Copeland equation was selected due to the fact that this equation is valid into the silt sized particles. The other equations available were developed for particle sizes in the sand range and above. Sand sized particles are defined as particles in diameter 0.0625 mm to 2 mm. Nearly 90% of the suspended sediment measured at the St. Paul gage was below the sand particle sizes.

DRAFT

Table 10: Sediment Transport Inputs Used in the HEC-RAS Model.

Loading							
	Apr	May	Jun	Jul	Aug	Sep	
Mississippi River							
Flow (cfs)	26900	21700	18900	14600	8870	8140	
TSS (mg/L)*	58.61	56.70	55.24	51.90	42.42	40.26	
8'x6' box							Total Sediment Load (tons)
Flow (cfs)	206	165	143	109	69	65	
Sediment Load (tons)	977	783	638	474	246	211	3,328
16' x 16' culvert							
Flow (cfs)	649	511	437	329	201	185	
Sediment Load (tons)	3,076	2,423	1,952	1,426	714	601	10,191
Bridge Option							
Flow (cfs)	971	732	611	438	256	237	
Sediment Load (tons)	4,604	3,468	2,731	1,899	907	772	14,382

*TSS values derived from equation in COE 2D Model Report

Figure 9: Bed Gradation Curve for Sediment Transport Analysis.

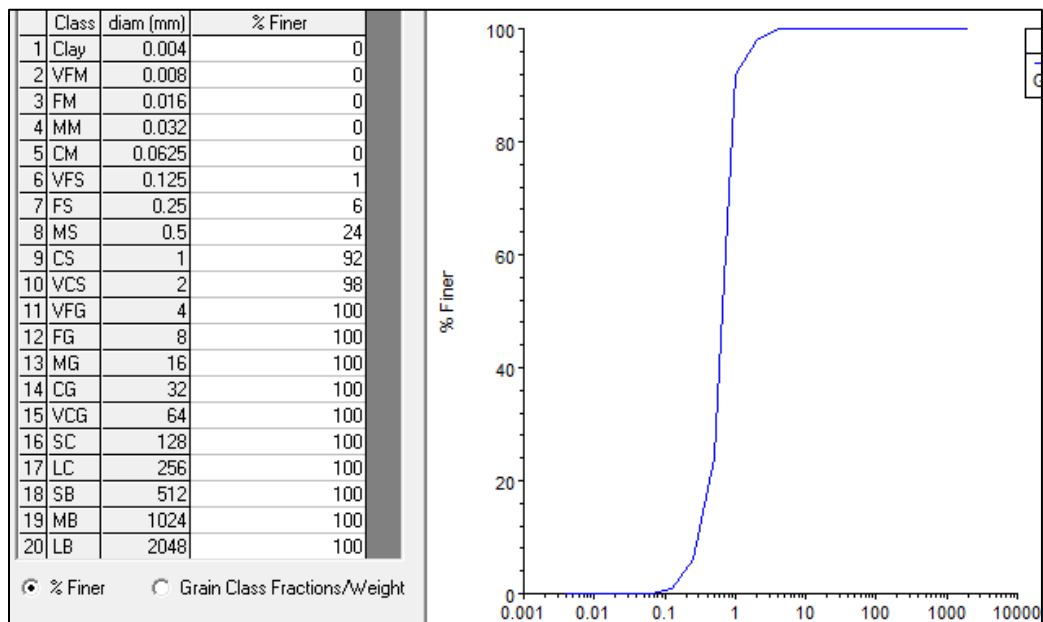

Table 11: Sediment Load (TSS) Grain Size Distribution.

percent <.002mm	percent <.004mm	percent <.008mm	percent <.016mm	percent <62.5um	percent <.125mm
40	51	59.5	69	89.5	100

*from USGS 05331000 Mississippi River at St. Paul, MN

The full results from the sediment transport analysis are shown in **Appendix D** for the model simulation period of April 1 to September 30. These tables show the estimated change in the channel bottom elevation at each cross section, as well as the change in sediment mass by cross section and cumulatively. The results for the change in channel bottom elevations are shown graphically in **Figure 10**. The upstream portion of the meander nearest the Mississippi River is only 2’-3’ in depth. This is currently caused by suspended sediment depositing as it enters the stagnant meander area. The analysis shows some small amount of lowering of the channel in this location with the increase in flow with large culvert and bridge alternatives. There will also be localized scour around the crossing for the bridge alternative. This is addressed by placing riprap under and around the bridge.

The analysis shows some sediment deposition through the lower end of the meander for the three alternatives. The deposition amount is small for each alternative; i.e., estimated at 0.01’ per year for the two culvert alternatives and 0.05’ feet per year for the bridge alternative. The model shows that the deposition occurring through the lower portion of the meander is due to the nominal widening of the meander. This widening of the channel is largely due to the tailwater resulting from Lock and Dam Number 2, and is therefore, not a true change in the geometry of the meander width. Without the dam present the channel would have a fairly uniform width throughout the reach.

Table 12: Sediment Transport Results Loading Summary April through September

	Total Incoming Sediment Load (tons)	Accumulated Mass April to September (tons)	Percent of Sediment Deposited in Reach
Small Culvert Alternative	3,329	1,072	32%
Large Culvert Alternative	10,191	2,328	23%
Bridge Alternative	14,381	5,150	36%

Figure 10: Sediment Transport Results Channel Invert Change April through September

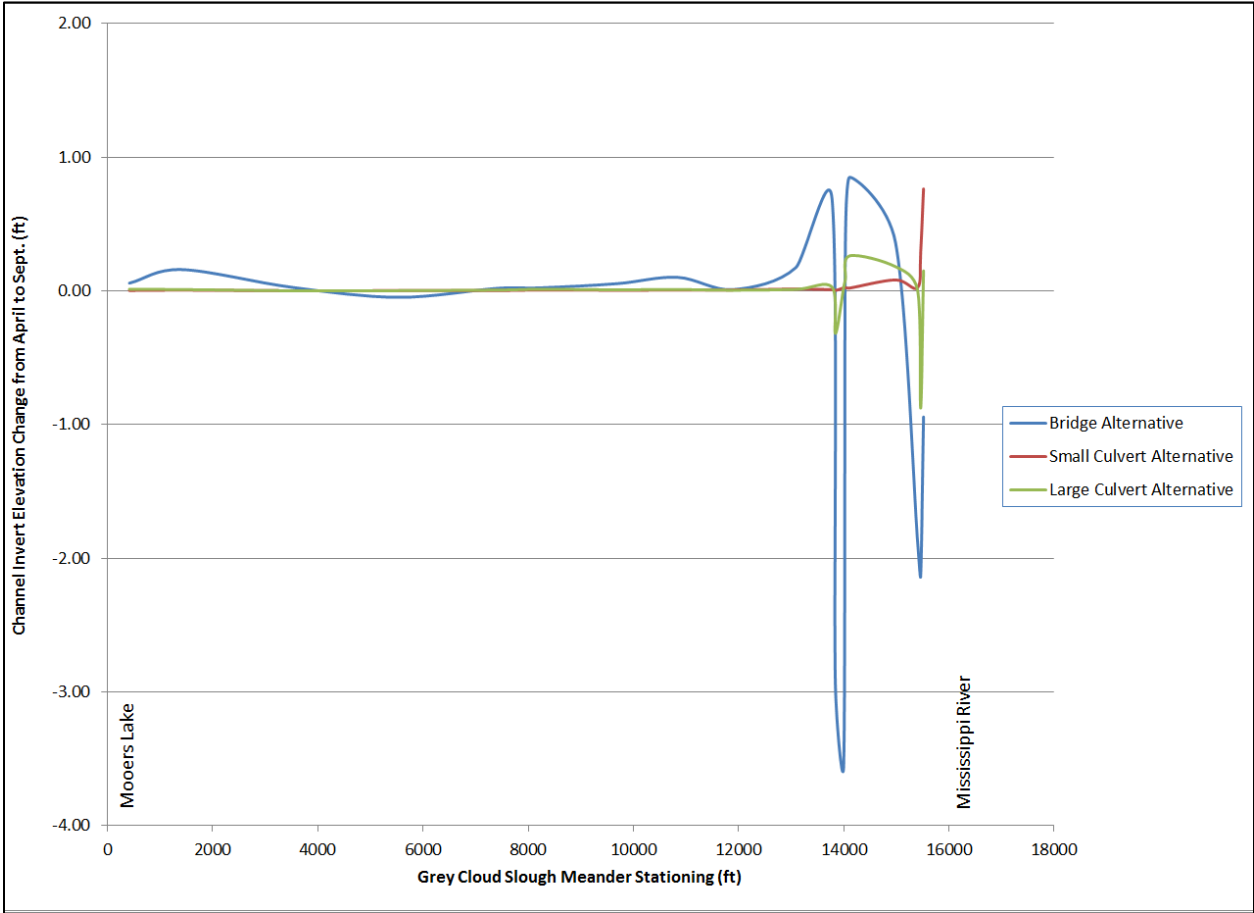

To evaluate whether erosion becomes an issue during larger flows HEI performed an analysis using the estimated 100-year discharge for the bridge option, assuming the discharged occurred for a 30 day period. The results of the analysis are shown in **Appendix D**. The results show some scour around the inlet to the meander in the same manner as shown in the previous analysis. The analysis again shows some local scour around the bridge. The analysis shows the remaining portion of the meander channel is “stable”, with no erosion and deposition occurring on the downstream end of the reach, similar to the results from the analysis using mean monthly discharge. Based upon the analysis regardless of the alternative the channel remains stable even in the larger flood events.

4.6 Water Quality

The water quality issues caused by the lack of connectivity with the Mississippi River are one of the primary reasons for the proposed meander restoration. The meander below Grey Cloud Drive commonly experiences large algae blooms and the amount of milfoil has increased through time. The result is a decrease in the types and abundance of fish and mussels. To evaluate water quality two approaches were used, which resulted in similar conclusions about the size of the opening needed to improve water quality.

DRAFT

4.6.1 Hydraulic Residence Time Analysis

One means of evaluating the potential change in water quality of the meander is by evaluating the amount of time necessary for water to move through the meander from the inlet to the confluence with Mooers Lake (i.e., the hydraulic residence time). Both the water quality of the Mississippi River and Mooers Lake currently influence and will continue to influence the water quality within the meander when an alternative is implemented. The longer water remains within the meander the more likely the water quality changes compared to the Mississippi River and to some extent compared to Mooers Lake. As the residence time through the meander declines biological and biogeochemical processes have less time to modify the quality of water entering the inlet from the Mississippi River. The primary biological processes which modify water quality is the growth and senescence of algae and aquatic plants. The amount of nutrients and dissolved oxygen are affected because algae and other rooted aquatic plants have less time to influence these levels as the residence time declines. Comparing the hydraulic residence time within the Mississippi River and Mooers Lake to the meander provides some means of assessing the desired flow rate within the meander.

Using the HEC-RAS model hydraulic residence times were estimated for the existing conditions for the Mississippi River from the meander mouth to the confluence of the Mississippi River with Moore's Lake and within Mooers Lake. Using the HEC-RAS model volumes within the Mississippi River and Mooers Lake were estimated for the median summer discharge. Because of the presence of Lock and Dam 2 and the influence on water level within the Mississippi River, the volume within the Mississippi River changes little for discharges less than 60,000 cfs. The volume within the Mississippi River and Mooer's Lake divided by the flow rate based on the HEC-RAS model is the hydraulic residence time. Results from the analysis are shown in **Table 13**. For the median summer flow the residence time in the Mississippi River is approximately 1.3 days and 10.6 days for Mooers Lake.

These hydraulic residence times provide a baseline for comparison to the hydraulic residence time for each of the proposed alternatives.

Using a range of flow rates, the volume within and the hydraulic residence time of the meander was estimated. **Table 14** shows the estimated hydraulic residence times for a range of discharges through the meander. For the meander to have a hydraulic residence time similar to the Mississippi River at the median summer flow, the minimum discharge necessary is an estimated 200 cfs. A discharge of approximately 20 cfs through the meander is necessary for the hydraulic residence time to be similar to the current hydraulic residence time within Mooer's Lake.

This analysis shows that a range of discharges from 20 to 200 cfs at the median summer flow will provide water quality in the Grey Cloud Slough channel consistent with the upstream and downstream waterbodies.

DRAFT

Table 13: Existing Estimated Hydraulic Residence Times for the Mississippi River and Mooer’s Lake.

Mississippi River		
from Grey Cloud inlet to Mooers lake outlet		
Volume: 26389.12 acre-feet @ median summer discharge		
Discharge (cfs)	Hydraulic Residence Time (days)	Flow Description
1000	13.3	
2620	5.1	Low Flow (5th Percentile Daily Flow May-Sept)
10300	1.3	Median Summer Flow (May-Sept)

Mooer’s Lake		
Volume: 2053.4 acre-feet @ median summer discharge		
Discharge (cfs)	Hydraulic Residence Time (days)	Flow Description
50	20.7	
21	49.3	Low Flow (5th Percentile Daily Flow May-Sept)
98	10.6	Median Summer Flow (May-Sept)
150	6.9	
539	1.9	5 year return period

Table 14: Grey Cloud Slough Estimated Hydraulic Residence Time Rating Curve.

Grey Cloud Slough Channel	
Below Grey Cloud Drive to Mooers Lake	
Volume: 406.49 acre-feet	
Discharge (cfs)	Residence Time (days)
0.5	409.9
10	20.5
20	10.2
30	6.8
40	5.1
50	4.1
80	2.6
100	2.0
250	0.8
1000	0.2

DRAFT

4.6.2 HEC-RAS Water Quality Simulation

The second water quality analysis performed consisted of simulating water quality within the meander using HEC-RAS version 4.1.0 as described in **Section 4.3**. The water quality module in HEC-RAS uses the QUICKEST-ULTIMATE⁹ explicit numerical scheme to solve the one-dimensional advection-dispersion equation. In order to simulate water quality a working HEC-RAS unsteady or steady flow model must already be in place. The model also requires inputs for meteorological parameters (e.g., solar radiation), water quality initial and boundary conditions, and a variety of rate coefficients. HEI used the model primarily for the purposes of simulating the total phosphorus and chlorophyll-a concentrations within the meander. While this analysis results in estimates of the concentrations of algae and total phosphorous, because the model is not calibrated to observed concentrations within the meander, the results should be used to gage the relative change in water quality (rather than the absolute change).

The model requires information about water quality at the boundary of the calculation domain (i.e., upstream on the Mississippi River at the inlet and downstream at Mooer's Lake) and the initial water quality within the meander. Two stations were evaluated to obtain these water quality data. These two water quality stations are located at the upstream end of the HEC-RAS model in St. Paul. The two stations are shown in **Table 15** and are within approximately a half mile of each other. The data for the two stations was combined and treated as one record, which is necessary to provide sufficient sample size dataset for all the required parameters. The average monthly data used for the boundary and initial conditions and the number of samples for the various parameters are shown in **Table 16**.

For this analysis, the water quality model was executed using a steady flow condition until no additional change in the concentration occurred, for the May through September period. The water quality data were from May through September and those values were used in the analysis, as shown in **Table 17**. While averages of the water quality data were used, the median flow was used for the analysis. The median values for the water quality data were computed for comparison purposes and found to be similar to the average values.

Default nutrient modeling parameters were used except for the maximum growth rate for algae was modified to 0.3 d^{-1} to keep the algae concentrations consistent with downstream measured concentrations with Mooer's Lake and on the Mississippi River. No downstream boundary condition was used for the modeling analysis (i.e. the solution was not forced to match any value at the downstream end). The average cell size used for computations was approximately 1000 feet on Grey Cloud, while the average cell size on Mississippi River was approximately 1200 feet. The dispersion coefficients used in the analysis were computed by HEC-RAS using data from the steady flow model runs.

⁹ Leonard B.P., 1991. The ULTIMATE Conservative Difference Scheme Applied to Unsteady One-Dimensional Advection, *Computer Methods in Applied Mechanics and Engineering*, vol 88, pp 17-74.

DRAFT

Table 15: Water Quality Data Stations Utilized in the HEC-RAS Model.

Station Name	MISS RIVER AT ST PAUL LAMBERTS LANDING
Alternate IDs:	UM839.1
Period of Record:	1985-1992
Total Number of Samples:	323

Station Name	MISS R AT DOCK UPSTRM OF WABASHA ST BR, ST. PAUL
Alternate IDs:	UM-840
Period of Record:	1973-2010
Total Number of Samples:	383

Table 16: Water Quality Data Used for the Initial Conditions and Boundary Condition at the Inlet to the Meander.

Average of Data (Number of Samples) by Month													May through Sept. Average
Parameter	Jan	Feb	Mar	Apr	May	Jun	Jul	Aug	Sep	Oct	Nov	Dec	
TP (mg/L)	0.12 (47)	0.11 (33)	0.25 (49)	0.21 (54)	0.23 (48)	0.26 (52)	0.25 (49)	0.23 (54)	0.20 (55)	0.14 (53)	0.13 (35)	0.13 (29)	0.23
Chlorophyll-a (µg/L)	9.86 (17)	12.77 (16)	23.01 (17)	50.22 (21)	62.21 (17)	40.83 (27)	39.04 (26)	54.56 (23)	53.92 (27)	44.76 (21)	29.13 (16)	23.88 (15)	50.11
BOD (mg/L)	1.75 (21)	2.04 (9)	3.75 (23)	3.71 (21)	3.22 (21)	2.83 (26)	3.47 (24)	3.45 (26)	3.06 (29)	2.83 (24)	2.68 (11)	2.12 (10)	3.20
DO (mg/L)	12.96 (46)	12.70 (33)	12.87 (66)	11.09 (69)	8.98 (63)	7.46 (67)	6.91 (65)	7.32 (69)	8.48 (70)	10.65 (70)	12.58 (37)	13.33 (33)	7.83
K nitrogen (mg/L)	1.16 (34)	1.08 (20)	1.58 (36)	1.49 (36)	1.51 (32)	1.62 (35)	1.66 (33)	1.47 (36)	1.26 (38)	1.21 (35)	1.25 (20)	1.18 (19)	1.51
Total N (mg/L)	1.53 (29)	1.04 (17)	2.48 (33)	3.25 (34)	2.56 (32)	3.97 (34)	1.51 (29)	1.62 (35)	0.95 (36)	1.37 (33)	1.53 (19)	1.70 (12)	2.12
Temp. (Deg. C)	0.50 (46)	0.97 (32)	3.00 (62)	9.96 (65)	18.28 (60)	22.52 (64)	25.19 (61)	23.36 (65)	18.48 (65)	10.91 (66)	4.77 (33)	1.04 (29)	21.57
Flow (cfs)	4,850	4,800	11,800	27,400	21,900	19,200	14,900	9,030	8,160	9,120	8,280	5,950	10,300*

* Median Flow for May through September was used

Table 17: HEC-RAS Water Quality Model Input Values and Rate Coefficients.

Parameter	Value used	Source in Water Quality Data
Water Temperature	21.57 deg C	Temperature
Algae	0.05011 mg/l	Chlorophyll-a
Dissolved Oxygen	7.83 mg/l	Dissolved Oxygen
Carbonaceous BOD	3.20 mg/l	BOD ₅
Organic Nitrogen	1.51 mg/l	Kjeldahl Nitrogen
Ammonium Nitrogen	0.00 mg/l	Assumed zero
Nitrite Nitrogen (NO ₂)	0.01 mg/l	Assumed detection limit of 0.01
Nitrate Nitrogen (NO ₃)	0.62 mg/l	Total N - KN
Organic Phosphorous	0.139 mg/l	TP x 0.60
Orthophosphate	0.093 mg/l	TP x 0.40

The results of the water quality simulations for a range of discharges and by alternative are shown graphically in **Figure 11** for the amount of algae (chlorophyll-a). The boundary with Mooers Lake is shown on the left of the graph and the inlet from the Mississippi River is shown on the right. No results are shown for existing conditions (i.e. no flow) because with the lack of flow the model is not numerically stable. Therefore a minimal flow of 14 cfs was used, which corresponds to the discharge through a 3’ diameter culvert under Grey Cloud Drive.

The model results show the algae concentrations in the Mississippi River near the inlet to the meander at 0.062 mg/L. For a flow of 14 cfs the highest concentration of algae within the meander increases to 0.22 mg/L. As the discharge through larger structures increases the algae concentrations decrease through the meander. Based upon this analysis at approximately 80 cfs a large portion of the water quality benefit is achieved; i.e., increase discharge does not markedly improve water quality. The estimate of 80 cfs is consistent with the range of discharges identified in **Section 4.6.1** based on analysis of the hydraulic residence time. The 8’ x 6’ culvert which provides the 80 cfs flow is the minimum opening size required for water quality for the small culvert alternative.

The results show that both the large culvert alternative and the bridge alternative result in a decrease in the algae concentrations, even though the decreases are small compared to the increase in opening size.

Figure 11: HEC-RAS Water Quality Results Graph of Chlorophyll-a Concentrations.

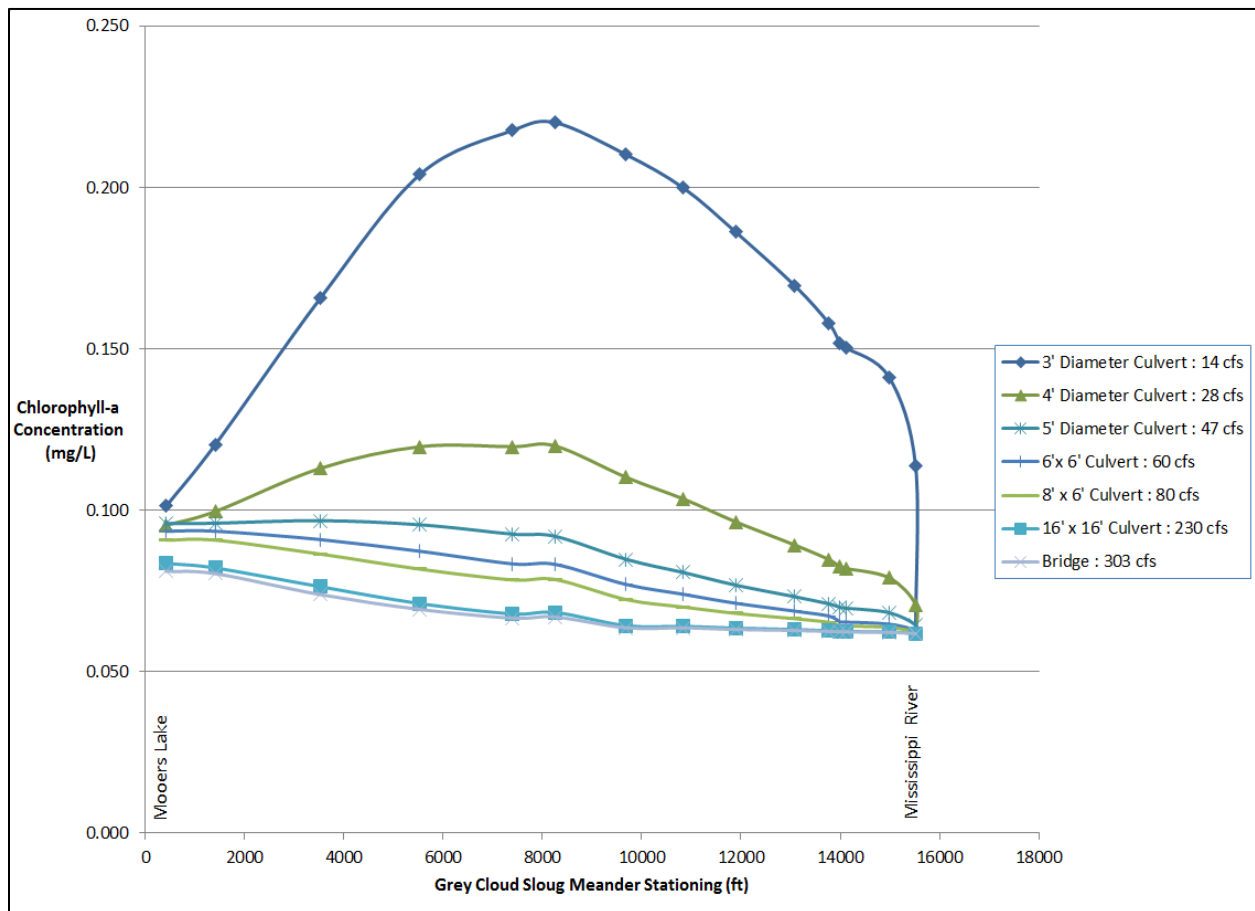

4.7 Navigability

The recreational boating design criteria described within **Section 2.2** are based on a design condition for the normal pool elevation. While this condition is present the majority of the time, periods of higher water will affect the navigability of the structure. During the TAC meeting DNR representatives presented their requirement for navigability, which is a low member elevation three feet above the 50 year flood elevation. The design criteria used for evaluating the alternatives does not meet the DNR criteria. The 50 year flood elevation on the upstream side of the road is approximately elevation 698.5. The top of road elevation is 701.5. The DNR recommendation would call for a low member elevation of 701.5, which would essentially eliminate the culvert option and require a total road raise of 2 feet for the bridge option. There is currently no desire by the County or Township to modify the existing vertical profile of the road, so the design criteria in **Section 2.2** will be used in place of the more restrictive DNR recommendation. In addition, the overall navigability of the Mississippi River is not affected by this project. So, while navigability to the Grey Cloud Slough meander will be affected during higher flows, it will not affect the overall greater recreation use of the Mississippi River.

DRAFT

Both the large culvert and bridge alternative provide the 12 foot horizontal clearance required (8 foot beam width with 2 feet of safety clearance on each side). At normal pool conditions, both alternatives also meet the 9 foot vertical clearance required (6 foot maximum height with 3 feet of safety clearance). The large culvert option has a vertical clearance of 9.13' and the bridge alternative a clearance of 12.63'. As flow increases the vertical clearance decreases as shown in **Table 18**. **Table 18** also presents the velocities through the structure as these will have an impact on how easily watercraft will navigate the channel. These velocities are quite high for the large culvert alternative, especially for the higher flows. The flows and clearances can be used to determine the percent of time during May through September the crossing would meet the recreational boating design criteria. The large culvert alternative meets the 9' vertical clearance to approximately 15,000 cfs or 60% of the time during May through September. The alternative would meet a 6' vertical clearance (no safety clearance) to approximately 40,000 cfs or 95% of the time. The bridge alternative meets the full 9' vertical clearance to approximately 60,000 cfs or 99% of the time.

Table 18: Navigability Vertical Clearances for Large Culvert and Bridge Alternatives.

Return Period	Miss. River Flow (cfs)	Large Culvert Alternative				Bridge Alternative			
		Low Member Elevation	Upstream Water Surface Elevation	Vertical Clearance	Velocity (fps)	Low Member Elevation	Upstream Water Surface Elevation	Vertical Clearance	Velocity (fps)
2 year	38,500	696	689.45	6.55'	7.46	700.5	689.22	11.28'	3.42
5 year	64,000	696	692.08	3.92'	10.3	700.5	691.72	8.78'	5.31
10 year	83,000	696	694.17	1.83'	10.94	700.5	693.75	6.75'	6.27
50 year	130,000	696	698.45	-2.45'	10.6	700.5	698.02	2.48'	7.06
100 year	150,000	696	699.99	-3.99'	10.41	700.5	699.54	0.96'	7.43
500 year	203,000	696	703.54	-7.54'	9.01	700.5	703.29	-2.79'	6.56
5th Percentile Flow	2,620	696	686.81	9.19'	0.44	700.5	686.81	13.69'	0.2
Median Summer Flow	10,300	696	686.66	9.34'	2.2	700.5	686.63	13.87'	0.91
Average April Flow	26,900	696	688.11	7.89'	5.58	700.5	687.96	12.54'	2.42
Average May Flow	21,700	696	687.52	8.48'	4.6	700.5	687.42	13.08'	1.96
Average June Flow	18,900	696	687.22	8.78'	4.03	700.5	687.14	13.36'	1.7

5 Analysis of Alternatives

This section describes the three alternatives in detail and presents the effectiveness of each alternative in achieving the project goals and design criteria. **Table 19** provides a summary of the four alternatives and provides a qualitative analysis of how each alternative achieves the design criteria. Descriptions such as “good” and “excellent” are subjective. The purpose of this table is to simply serve as a guide and aid in the decision making process. Details are provided in the following sections, including Opinions of Probable Cost and Preliminary Engineering Drawings.

Table 19: Alternative Analysis Matrix.

Alternative	Design Criteria						
	Connectivity	Fish Passage	Geomorphic Stability	Water Quality	Overtopping Frequency	Embankment Stability	Recreational Navigability
	Ecological			Transportation		Navigation	
No Action	None	None	Same as Current	No Change	Same as Current	Same as Current	None
Small Culvert	Some	Some	Stable, Small Increase Sedimentation	Good	Same as Current	Improved	None
Large Culvert	Good	Feasible With Suitable Substrate	Stable, Small Increase Sedimentation	Excellent	Same as Current	Improved	Good
Bridge	Excellent	Excellent	Stable, Small Increase Sedimentation	Excellent	Slightly Improved	Improved	Excellent

DRAFT

5.1 Small Culvert Alternative

The small culvert alternative is solely sized to meet the water quality goals, while not achieving the secondary goals of recreational boating navigability. While this option reestablishes the longitudinal connectivity of the system, very little lateral connectivity to the riparian areas is achieved due to the small amount of flow in the channel. Water will flood the riparian areas due to the tailwater on the channel, but little or no flow would be found in these overbank areas. Velocities in the downstream cross section are very low, less than 0.5 feet per second even during large flood events.

Fish passage through this structure is limited to a Mississippi River flow of approximately 14,600 cfs. It is likely that this structure will not allow fish passage during a normal spring flood as velocities through the structures will simply be too large. It may be possible to place material inside the culvert such as riprap or pre-cast concrete blocks to roughen the bed surface to create resting areas for fish. While these materials aid fish passage they also increase the likelihood debris related problems and clogging of the culvert. If these objects were displaced over time they would be nearly impossible to replace.

Water quality within the meander is improved considerably for this alternative. The large algae blooms which currently occur are expected to be reduced with water quality approaching that of Mooer's Lake or even slightly better.

This alternative would be constructed by installing a small culvert at the invert elevation of approximately 680. This accounts for an over-excavation of 3' below the culvert where geotextile fabric and 3' of stabilizing aggregate would be placed. This is to account for the poor soils observed in the soil boring logs (**Appendix B: Soil Boring Logs**). A sheet-pile cutoff wall is planned on the upstream side of the culvert to prevent seepage and piping under the culvert. The use of the stabilizing aggregate and cutoff walls would need to be confirmed once the final geotechnical analysis is completed.

The excavation down to elevation 680 is approximately 8' below the normal water surface requiring dewatering. Dewatering typically consists of using sheetpile around the excavated area and pumping the water out of the excavation area. Due to the depth of water that needs to be removed, poor soils, and relatively large area to dewater this cost is expected to be high. The estimated cost for dewatering is \$50,000 as shown in the Preliminary Opinion of Probable Construction Cost (POPCC) (see **Table 20**). The POPCC for the alternative is \$278,000.

Approximately 100' of roadway requires replacing due to the excavation for the culvert. The original horizontal and vertical alignment of the road will remain the same. In addition some side sloping along the road is necessary as shown in **Figure 12**. A small amount of fill will need to be placed in the water for the proposed alternative most likely 1 or 2 feet wide on each side for a length of approximately 50 feet. New guardrail will be installed on each side of the road. The installation of the guardrail is necessary for a roadway embankment as narrow as possible and the placement of as little fill (below the water level) as possible.

This alternative includes installation of a safety grate. While placing a grate over the culvert will increase maintenance, the grate is essential for safety reasons. Only two feet of the culvert will be

DRAFT

exposed during normal pool conditions and velocities through the culvert will remain high for almost all flows.

During excavation for placement of the culvert, some of the voids encountered in the soil borings would be removed. It is expected that the overall stability of the embankment would be improved by replacing some of these problem areas with compacted fill. The hydrostatic pressure across the road will still be present since the small culvert will not alter the upstream or downstream water surface elevations.

Table 20: Preliminary Opinion of Probable Construction Cost for the Small Culvert Alternative.

Mobilization	\$40,000
Culvert	\$123,000
Roadway	\$40,000
Dewatering	\$50,000
Traffic Control	\$20,000
Seeding/Erosion Control	\$5,000
<hr/>	
Total Construction Cost	\$278,000
<hr/>	
Construction Contingency (20%)	\$56,000
Design, Bidding, Construction Management (20%)	\$56,000
Geotechnical	\$12,000
Permitting	\$15,000
Administrative/Legal (15%)	\$20,000
Environmental Mitigation (0.25 acre)	\$13,000
<hr/>	
TOTAL COST	\$450,000

5.2 Large Culvert Alternative

The large culvert alternative is sized to meet both the water quality goals and the secondary goal of recreational boating navigability. The culvert size is essentially one of the larger box culvert manufactured which can be transported by truck to the site; i.e., a 16' x 16' reinforced concrete box culvert. The 16' x 16' culvert presents challenges due to its size, both in shipping to the site and placement. Shipping is usually done at night, and a very large crane is typically required during placement.

This alternative provides the longitudinal connectivity of the system and some limited lateral connectivity to the riparian area. Velocities in the downstream cross section are still somewhat low, ranging from 0.5 to 1.25 feet per second even during large flood events.

Fish passage through this structure is improved over the small culvert alternative, but is limited to a Mississippi River flow of approximately 18,300 cfs without roughing the substrate of the culvert with rip-rap or large rock or some other means. This alternative is unlikely to allow fish passage during a normal spring flood (without additional roughened channel bottom), as velocities through the structures will simply be too high. This is a viable option to allow for fish passage. The additional obstructions that would need to be added for fish passage are not included in the POPCC.

Water quality within the meander is improved considerably for this alternative compared to the small culvert alternative. The large algae blooms which currently occur are expected to be reduced with water quality exceeding that of Mooer's Lake.

This alternative would be constructed by installing a large culvert at an invert elevation of approximately 677. This elevation accounts for over-excavation 3' below the culvert bottom where geotextile fabric and 3' of stabilizing aggregate would be placed. This is to account for the poor soils observed in the soil boring logs (**Appendix B: Soil Boring Logs**). A sheet-pile cutoff wall is planned on the upstream side of the culvert to prevent seepage and piping under the culvert. Similar to the small culvert alternative, the assumptions of the stabilizing aggregate and cutoff walls would need to be reviewed once the final geotechnical analysis is completed.

Excavation to elevation of 677 is approximately 11' below the normal water surface and will require dewatering during construction. Due to the depth of water that needs to be removed, poor soils, and the relatively large area to dewater this cost will again be fairly high. The estimated cost for dewatering is \$75,000 as shown in the POPCC (see **Table 21**). The POPCC for the large culvert alternative is \$489,000.

Approximately 125' of roadway needs to be replaced due to the excavation. The original horizontal and vertical alignment of the road will remain the same. Some side sloping along the road is needed as shown in **Figure 13**. A small amount of fill is needed, most likely 1 or 2 feet wide on each side of the road for a length of approximately 65 feet. A new guardrail will be installed on each side of the road for safety which also allows for a roadway embankment as narrow as possible and placement of as little fill in the water as possible.

DRAFT

During construction some of the voids encountered in the soil borings would be removed. It is expected that the overall stability of the embankment would be improved by replacing some of these problem areas with compacted fill. The hydrostatic pressure across the road will still be present for the most part since the culvert will not significantly alter the upstream or downstream water surface elevations.

Table 21: Preliminary Opinion of Probable Construction Cost for the Large Culvert Alternative.

Mobilization	\$60,000
Culvert	\$284,000
Roadway	\$44,000
Dewatering	\$75,000
Traffic Control	\$20,000
Seeding/Erosion Control	\$6,000
<hr/>	
Total Construction Cost	\$489,000
<hr/>	
Construction Contingency (20%)	\$98,000
Design, Bidding, Construction Management (20%)	\$98,000
Geotechnical	\$12,000
Permitting	\$15,000
Administrative/Legal (15%)	\$35,000
Mitigation (0.25 acre)	\$13,000
<hr/>	
TOTAL COST	\$760,000

DRAFT

5.3 Bridge Alternative

The bridge alternative is capable of achieving both the recreational boating navigability and water quality requirements. However, the geotechnical and road geometry requirements typically define the opening dimension, which remains true in this particular case. The bridge alternative consists of a concrete slab span with a thickness of approximately two feet. (The selection of the bridge type is discussed in **Section 3.4.**) The bridge length is 102' and comprised of three spans. The middle longest span is envisioned as 40' in length. The piers are expected to consist of circular steel pile. A plan and profile view of the bridge is shown in **Figure 14.**

Washington County Public Works Department during the TAC meeting requested the low chord of the bridge at one foot above the 100 year flood elevation. Based upon the hydraulic modeling (see **Section 4.3**) the 100 year flood elevation on the upstream side of the bridge is elevation 699.5 (NAVD88), meaning a low chord elevation 700.5. For a bridge of this length a 2' structure depth (i.e. the distance from top of road to the low chord) is assumed. Therefore the new top of road elevation is approximately 702.5, compared to the current top of road elevation of 701.5. A road raise of approximately 1' for a length of approximately 600' is therefore needed.

The low chord elevation requirement by the County is different than the requirements identified in the MNDOT State Aid Bridge Handbook. This could be revisited if a lesser requirement is thought to be appropriate for this crossing.

The horizontal curve on the east side of the proposed crossing presents a challenge for the bridge alternative. A curved bridge can be constructed, but generally avoided for cost and constructability reasons. Most curved bridges are steel girder bridges, a type of bridge not considered for the feasibility study due to the increased structure depth and associated increase in cost. The bridge can be constructed with extra width to allow some encroachment into the curve. For the POPCC the bridge is assumed to be an additional two feet wide. The location of the bridge is centered on the downstream channel, but slightly off-center of the upstream channel. The stream centerline shown on the preliminary engineering drawings consists of alignment through the roadway that compromises between the upstream centerline and downstream centerline. Additional riprap will be placed on both sides of the upstream side of the bridge to provide erosion protection for the increased water velocity because of a 90 degree turn to the south as the water passes through the bridge opening.

This alternative provides for the longitudinal connectivity of the system and good lateral connectivity to the riparian area. Velocities in the downstream cross section are over 1 foot per second in nearly every cross section for all flood events.

Fish passage through this structure is possible up to a Mississippi River flow of 59,400 cfs. However, it is likely the structure would be passable for nearly all flows due to the refuge provided by the bridge piers and the riprap substrate. This alternative provides the best longitudinal connectivity for fish and invertebrates as there will be no concrete floor to the structures. The riprap placed below the bridge will provide for a resting place for fish as they traverse the structure. The alternative results in marginally improved water quality compared to the large culvert alternative.

DRAFT

This alternative would be constructed by excavating the existing roadway embankment to an elevation of approximately 678 for a width of 20' and carrying up the excavation at a side slope of 2:1. (Note: the 2:1 side slope assumption is discussed in the preliminary geotechnical assessment (**Appendix A**)). The allowable side slope under the bridge is very crucial as it largely determines the length of the bridge. The side slope assumption needs confirmation when the final geotechnical analysis is complete. A more mild side slope requires a longer bridge and greater cost.

The excavation to elevation 678 is approximately 10' below the normal water surface but should not require dewatering. The area will be excavated and a geotextile placed by weighting it down with riprap. The estimated construction cost is \$752,000 as shown in the POPCC (see **Table 22**). The POPCC includes approximately 300 cubic yards of additional riprap for the upstream side of the bridge.

Approximately 600' of roadway needs to be replaced due to the one foot of road raise required to meet the low member clearances. The original horizontal and vertical alignment of the road will remain the same except the bottom of the vertical profile raised one foot. In addition some side sloping along the road is needed as shown in the Preliminary Engineering Drawings for this alternative (see **Figure 14**). A small amount of fill is also needed to increase the road width 2 or 4 feet wide on each side for a length of approximately 40 feet.

For comparison purposes and discussion among TAC members, another option comparable to the Bridge Alternative may be considered. A variety of propriety options exist, but a product similar to Contech's Con-Span may be best suited for this project. A photograph and schematic of this type of structure is shown in **Figure 15**. The structure is essentially a pre-cast concrete bridge placed on footings in four foot wide sections. Fill is placed over the structure and the regular paved roadway is placed over the top. The major benefit to this type of structure is there is no bridge deck to maintain. The construction time is also typically quicker for this than a concrete slab span bridge.

As can be seen in **Figure 15**, the rounded arch top of the structure is considered more aesthetically pleasing by some than a "normal" bridge. Preliminary sizing and costs were evaluated at for this option. The structure best suited for this application has approximate span of 50' and a center rise of 11' above the footings. Even though the span is 50' as compared to the 100' span for the bridge, the recreational boating navigability for the two alternatives is essentially be the same due to the two piers that would be placed under the bridge. Due to the poor soils the bottomless culvert option would require a deep foundation increasing the cost. A cost estimate was prepared for the bottomless culvert option and was found to be about 5% less than the bridge alternative. This most likely falls within the contingency for the POPPC's, so the bridge and bottomless culvert option can be considered the same cost.

Table 22: Preliminary Opinion of Probable Construction Cost for the Bridge Alternative.

Mobilization	\$60,000
Bridge	\$511,000
Roadway	\$111,000
Additional Riprap	\$33,000
Traffic Control	\$20,000
Seeding/Erosion Control	\$17,000
Total Construction Cost	\$752,000
Construction Contingency (20%)	\$150,000
Design, Bidding, Construction Management (20%)	\$150,000
Geotechnical	\$12,000
Permitting	\$15,000
Administrative/Legal (15%)	\$53,000
TOTAL COST	\$1,132,000

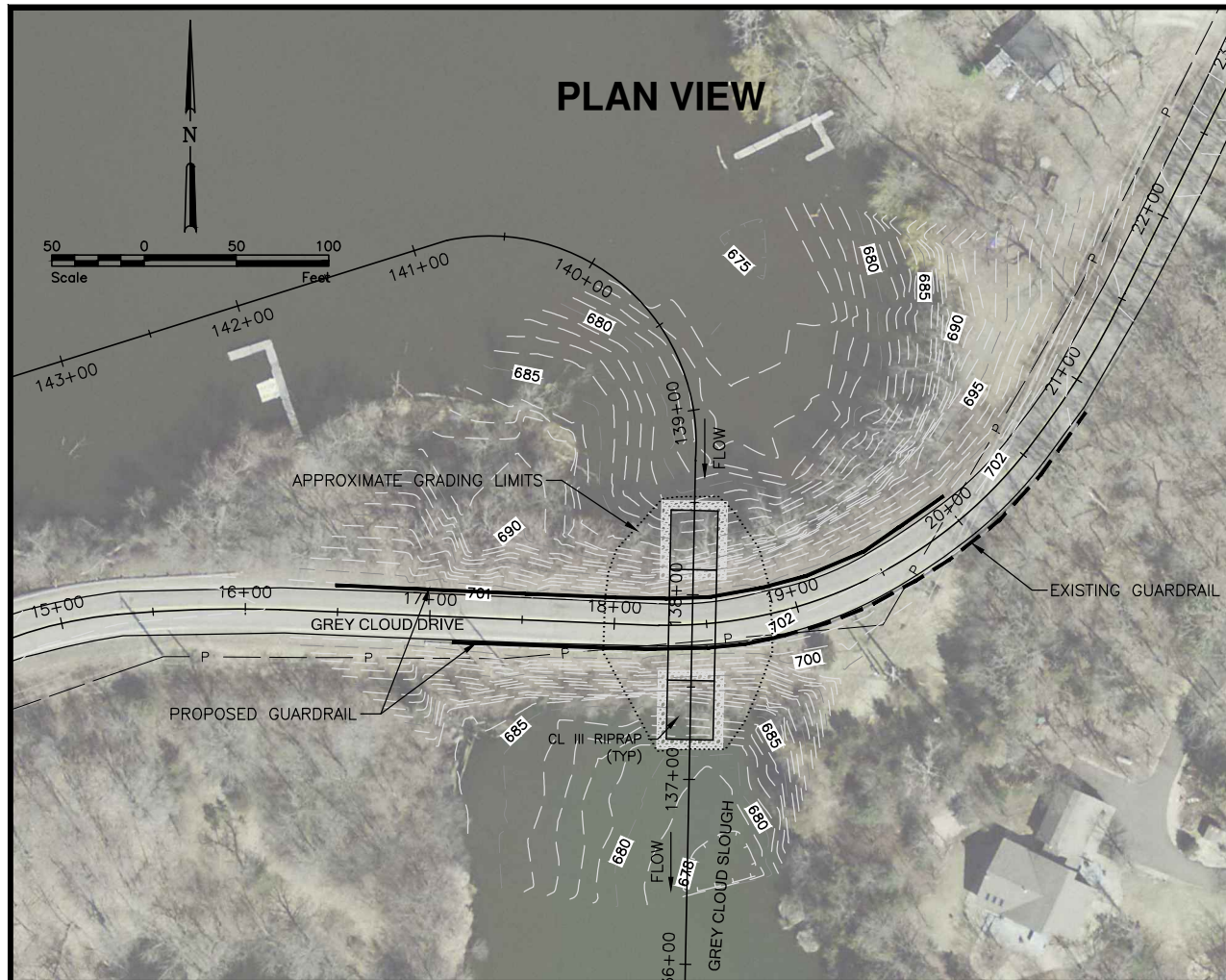

NOTES

- HORIZONTAL CONTROL:** ANY COORDINATES LISTED IN THIS PLAN ARE WASHINGTON COUNTY, MINNESOTA DOT, US FOOT.
- VERTICAL CONTROL:** ALL ELEVATIONS ARE NORTH AMERICAN VERTICAL DATUM OF 1988 (NAVD 88).

ASSUMPTIONS

- 2:1 SIDE SLOPES ALONG THE ROADWAY ARE ADEQUATE.
- A 3' DEPTH OF STABILIZING AGGREGATE WITH GEOTEXTILE IS ADEQUATE TO SUPPORT THE CULVERT. NO DRIVEN PILE IS REQUIRED FOR SUPPORT.

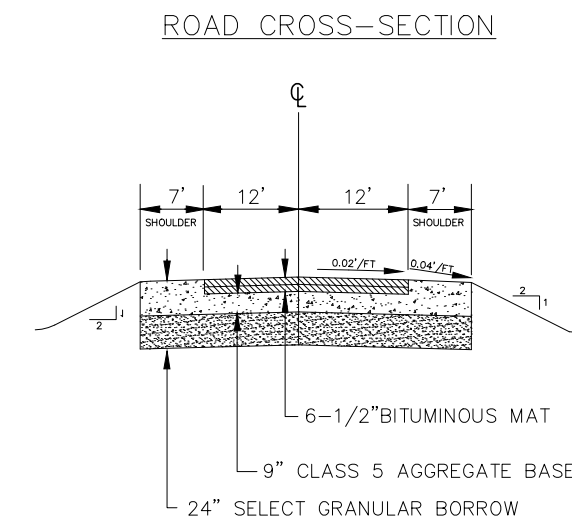

PRELIMINARY

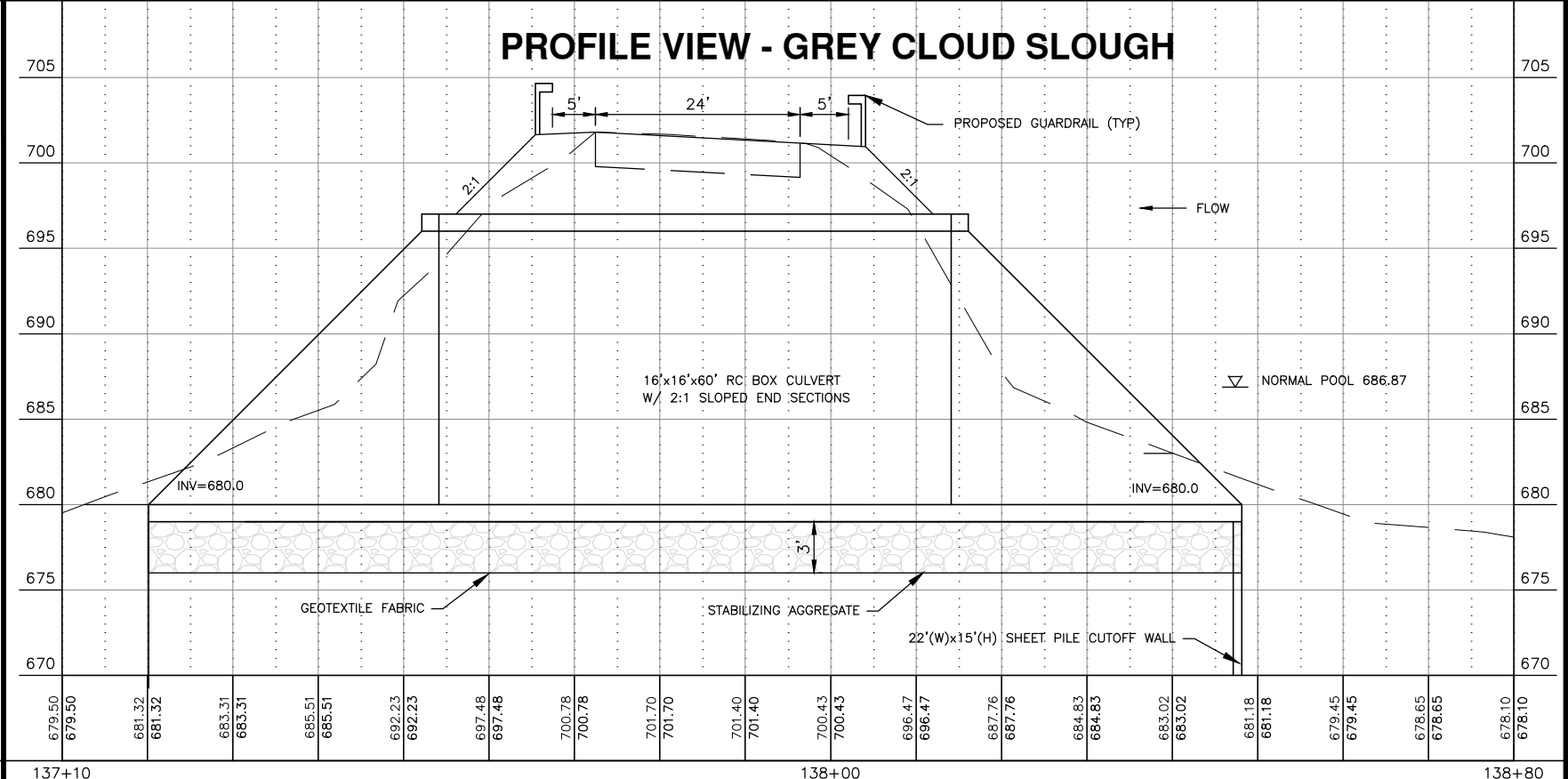
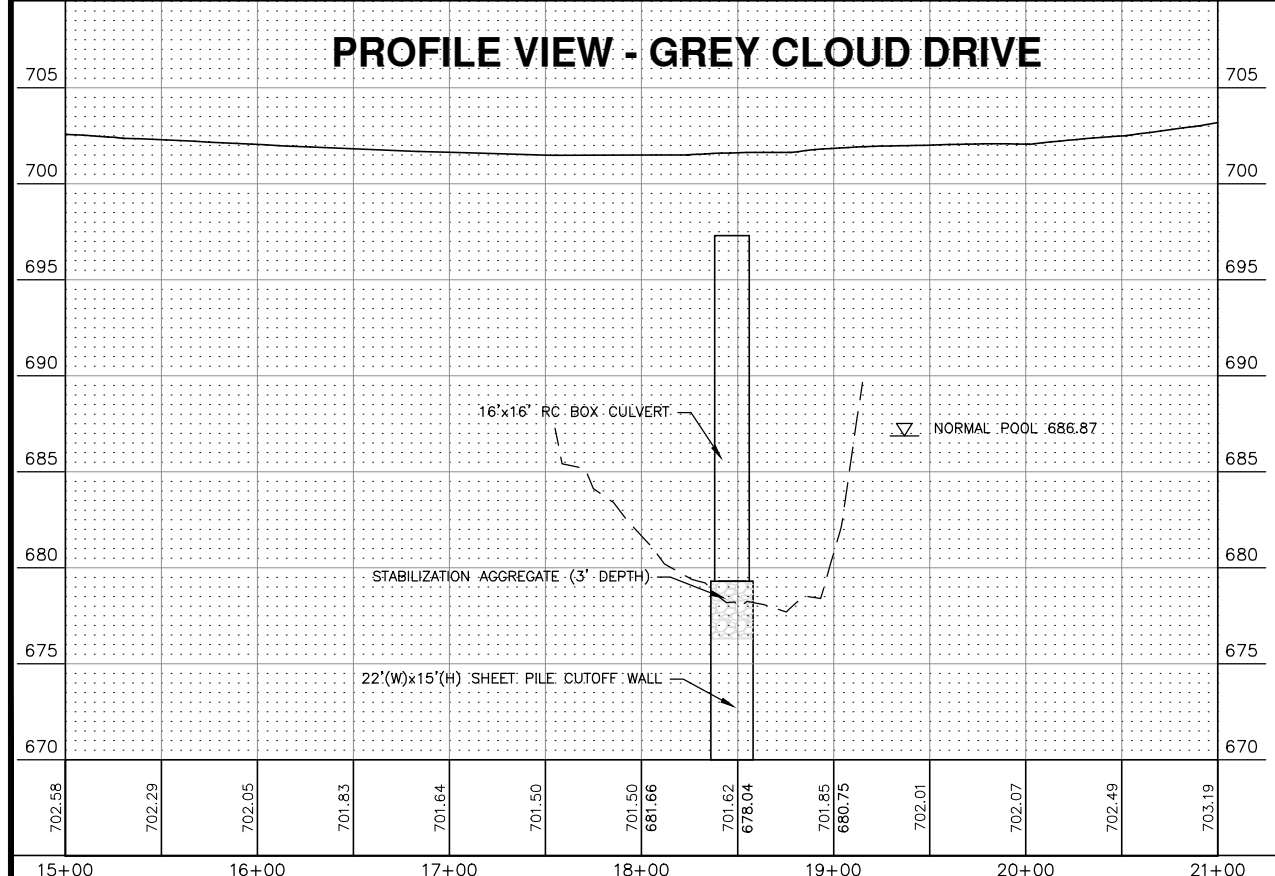

No.	Revision	Date	By

I hereby certify that this plan, specification, or report was prepared by me or under my direct supervision and that I am a duly Licensed Professional Engineer under the laws of the State of Minnesota.
 Signature: _____ Date: X-XX-XXXX
 Printed Name: XXXXXX X, XXXXXX License #: 000000.



Maple Grove
 Drawn by CCO
 Date 3-6-12
 Checked by ML
 Scale AS SHOWN

GREY CLOUD SLOUGH RESTORATION FEASIBILITY
 COTTAGE GROVE, MN
 SOUTH WASHINGTON WATERSHED DISTRICT

FIGURE 13
 LARGE CULVERT ALTERNATIVE
 PROJECT NO. 4876-015

SHEET

S:\4876-015_GreyCloudSloughRestoration\CAD\Final\option2-navigable_culvert.dwg 7/8/12 11:44 AM Plo Date: 4/19/2012 11:45 AM (jbowles)

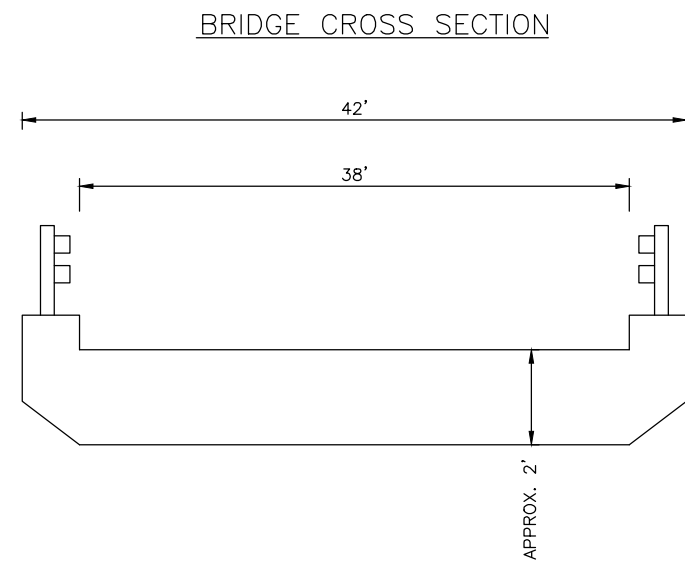
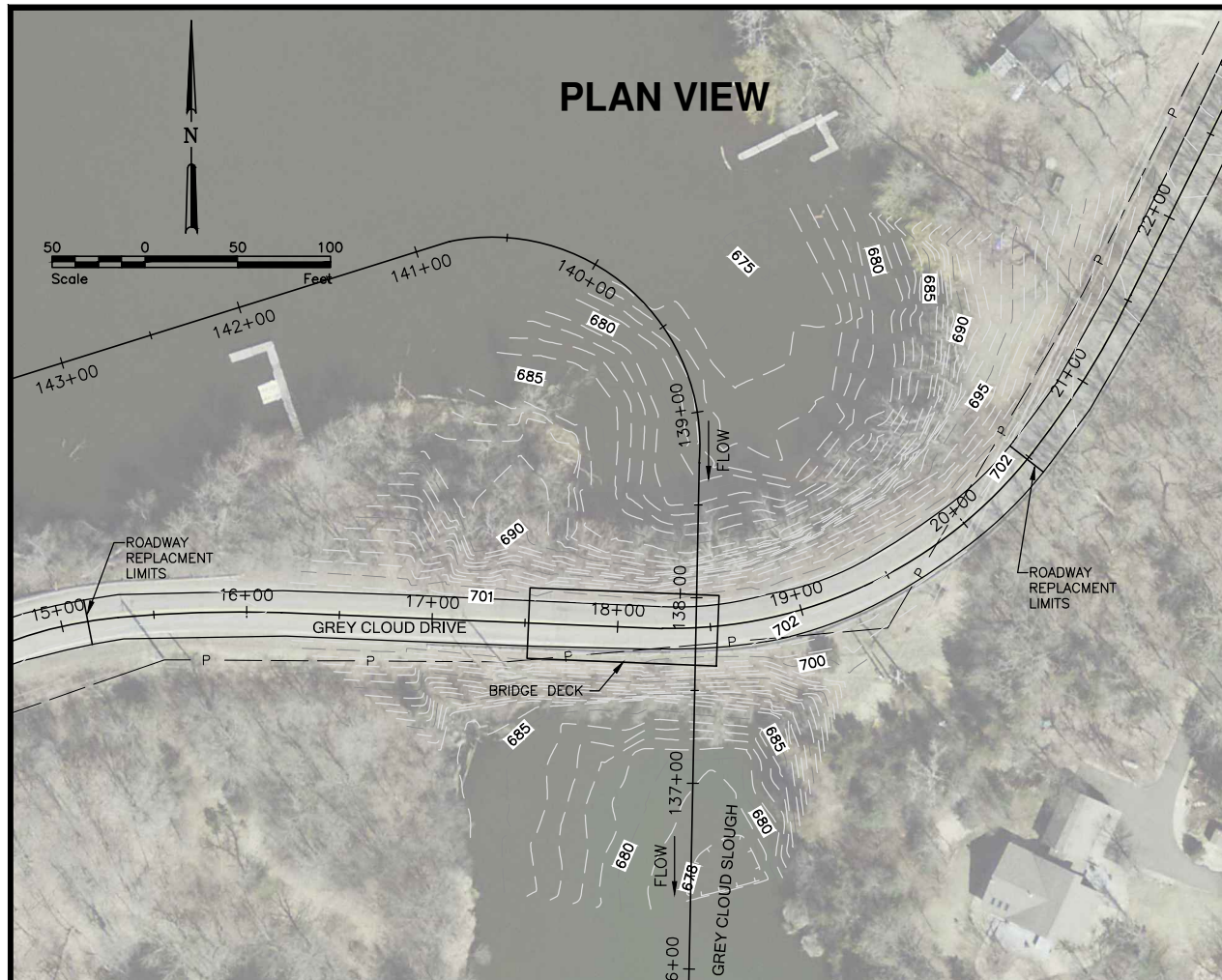

NOTES

1. HORIZONTAL CONTROL: ANY COORDINATES LISTED IN THIS PLAN ARE WASHINGTON COUNTY, MINNESOTA DOT, US FOOT.
2. VERTICAL CONTROL: ALL ELEVATIONS ARE NORTH AMERICAN VERTICAL DATUM OF 1988 (NAVD 88).

ASSUMPTIONS

1. 2:1 SIDE SLOPES ALONG THE ROADWAY ARE ADEQUATE.
2. 2:1 SIDE SLOPES IN THE CHANNEL UNDER THE BRIDGE ARE ADEQUATE.

PRELIMINARY

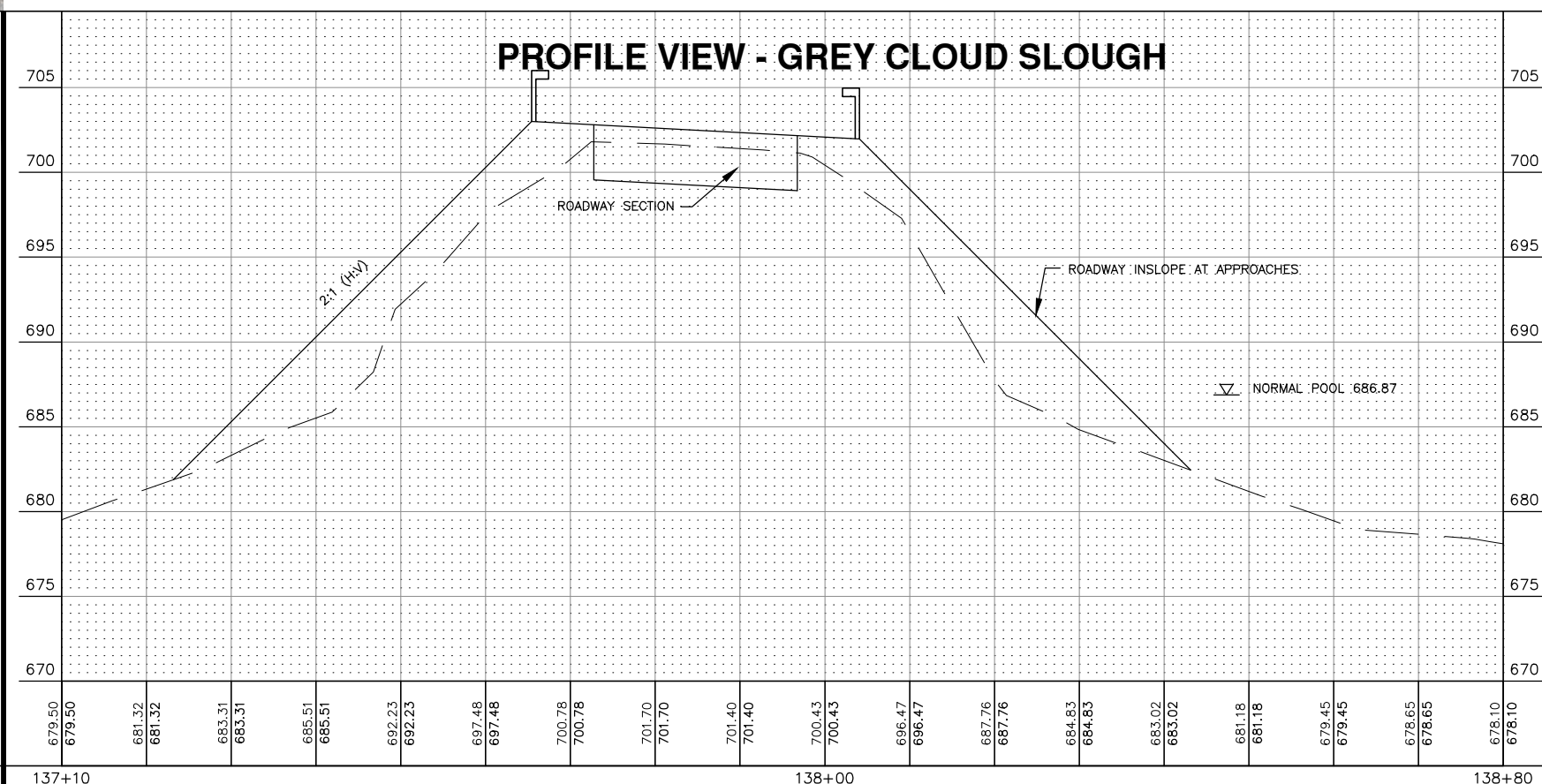
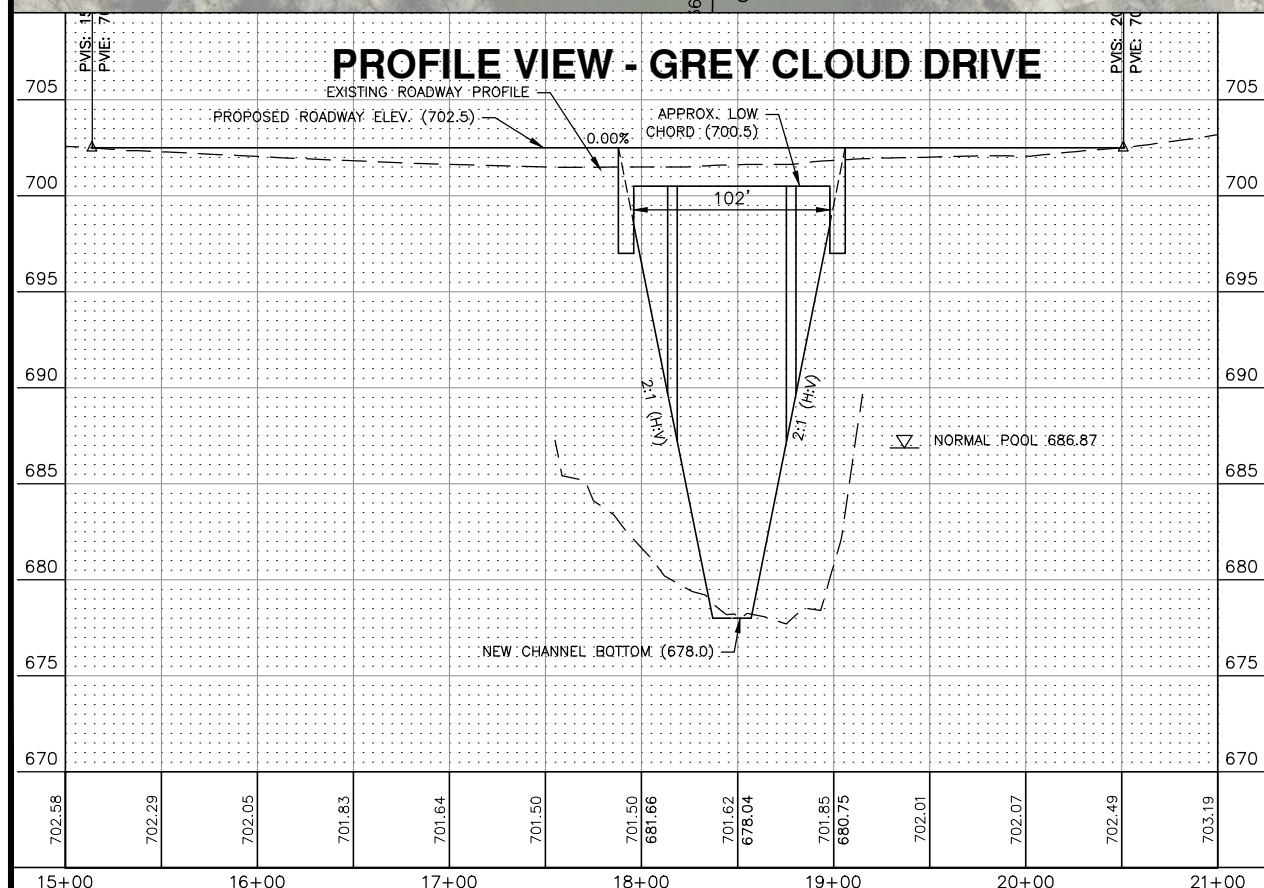

S:\4876-015_GreyCloudSloughRestoration\CAD\Final\options3-bridge.dwg P&P_Save_Date:4/19/2012 11:46 AM Plot_Date:4/19/2012 11:46 AM (gbowles)

No.		Revision		Date	By	I hereby certify that this plan, specification, or report was prepared by me or under my direct supervision and that I am a duly Licensed Professional Engineer under the laws of the State of Minnesota. Signature: _____ Date: X-XX-XXXX Printed Name: XXXXXX X, XXXXXX License #: 000000.		Maple Grove		Drawn by CCO	Date 3-6-12	GREY CLOUD SLOUGH RESTORATION FEASIBILITY COTTAGE GROVE, MN SOUTH WASHINGTON WATERSHED DISTRICT	FIGURE 14 BRIDGE ALTERNATIVE PROJECT NO. 4876-015	SHEET
										P: 763.493.4522 F: 763.493.5572	Checked by ML			

Figure 15: Photograph and Schematic of Pre-Cast Bottomless Culvert.

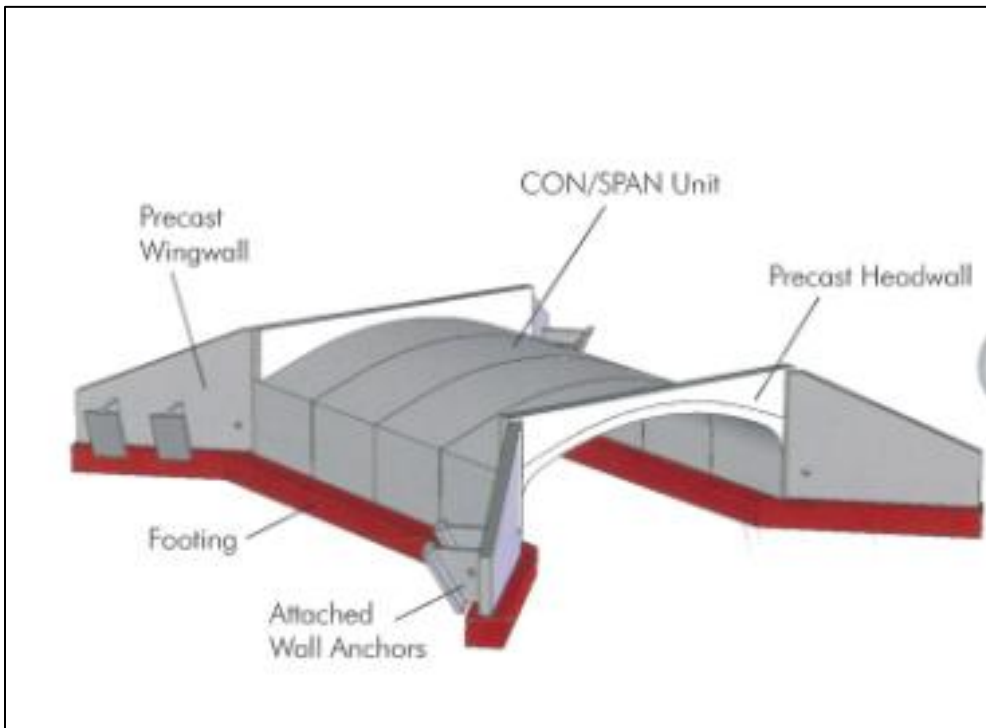

6 Environmental Impacts and Permitting

6.1 Permitting

6.1.1 Federal

Impacts to waters and wetlands from construction activities are regulated under multiple levels of government. An impact, under most circumstances, is considered excavation within or placement of fill within a water or wetland. Under Federal Law, the US Army Corps of Engineers may regulate the proposed project features under Section 10 of the River and Harbors Act and/or Section 404 of the Clean Water Act (CWA). Section 10 of the Rivers and Harbors Act prohibits unauthorized obstruction or alteration in or over any navigable waters of the United States. Section 404 of the CWA regulates the discharge of dredged or fill material of waters of the United States. A “General Form for Most Projects Involving Lakes, Wetlands, Rivers and Streams” will need to be prepared and submitted to the US Army Corps of Engineers to obtain the permit required for these activities.

6.1.2 State

Under state government authority, a Public Waters Work Permit from the Department of Natural Resources Public Waters will be necessary for all work proposed below the Ordinary High Water (OHW) level within the Public Waters and Public Water Wetlands (Minnesota Statues 103G). Wetlands in existence above the OHW will be regulated by the Minnesota State Wetland Conservation Act (WCA), implemented by the Board of Water and Soil Resources. The presence or absence of wetlands above the OHW will require field verification. Any impacts to wetland resources will require mitigation under state and federal law. This segment of the Mississippi River is not identified within the Wild and Scenic Rivers program of Minnesota. A “General Form for Most Projects Involving Lakes, Wetlands, Rivers and Streams” will need to be prepared and submitted to the state Local Government Unit (LGU) to obtain the necessary permit for these activities.

6.1.3 Local

A floodplain alteration permit may be required from Washington County. The Washington County Shoreland Management Ordinance regulates 1,000 feet from the normal high water mark of a lake, pond, flowage, river, stream or the landward extent of a floodplain designated by ordinance on such river or stream, whichever is greater. A permit may be required for grading, filling, and excavation work within the shoreland from the Washington County zoning administrator and/or the Department of Natural Resources.

6.1.4 Summary

No immediate permit concerns are evident. Restoration projects generally tend to be viewed favorably by the resource agencies and permits are generally easy to obtain. Expectations are that the work could be authorized by the COE under a General Permit or Letter of Permission.

6.2 COE Mississippi River Operational Considerations

Through consultation with the COE¹⁰ one concern is related to whether an increase in dredging maintenance around the upstream end of the Grey Cloud Slough channel is needed if flow is restored to the channel. The primary concern is that as flow is diverted into the Grey Cloud channel there is less flow to move the sediment further downstream in the Mississippi River and sediment deposition will occur. This is primarily a concern for lower flows where the Grey Cloud channel will receive very little of the sediment bed load. Based on the modeling performed, the largest percentage of the flow diverted under median summer flow conditions is 2.9% of the total flow for the bridge alternative and less for the other alternatives. There is a decrease in the velocity in the Mississippi River of approximately 2% caused by the bridge option. Channel velocities in the Mississippi River during the median summer flow are approximately 0.9 feet per second around the inlet to Grey Cloud Slough. It would be difficult to determine if a decrease this small would have any effect on the dredging maintenance schedule. Restoring flow into Grey Cloud Slough has been identified as a priority in COE documents regarding restoration of Mississippi River Pool 2. Most notably the “Lower Pool 2 Restoration Project” finalized on July 21, 2010. Any small increase in dredging maintenance would most likely be outweighed by the ecological benefits of the restoration.

¹⁰ Scott Goodfellow, personal communication with Mike Lawrence, on March 23, 29 and April 3, 2012.

7 Project Feasibility and Engineer's Recommendation

7.1 Project Feasibility

The determination of project feasibility is based upon several design criteria established by the Engineer in consultation with the TAC. These criteria include:

- The ability to attain the project goals presented in **Section 2** of this report;
- An understanding of the perceived magnitude of the potential environmental impacts and the likelihood of obtaining the necessary regulatory approvals and permits;
- The perceived constructability of the project;
- Cost.

Based upon the information presented in this report, it is the opinion of the Engineer that all three alternatives are feasible using the above design criteria. All of the alternatives will achieve the primary design goal of addressing the water quality issues in the Grey Cloud Slough meander. The small culvert alternative does not achieve the secondary goals related to providing for recreational boating navigability. There will not be an unacceptable adverse resource impact as a result of this project. The project is in fact expected to have many beneficial environmental benefits. Each of the alternatives presented in **Section 5** can be constructed with normal construction practices. While there are challenges related to the project, particularly from a geotechnical standpoint, these issues are considered manageable.

Both capital and maintenance costs can be considered when assessing project feasibility. There was no specific quantitative criterion established related to project cost. Generally, project cost is evaluated relative to other, similar type projects. There is a typically a strong relationship between the constructability of a project and the project cost. Based on the estimated POPCCs the cost for all three alternatives is considered "reasonable" as the project costs fall within similar type projects.

7.2 Engineer's Recommendation

Considerable technical analyses have been completed to evaluate the various alternatives for the proposed Grey Cloud Drive crossing. The small culvert alternative is the least costly alternative and will address the water quality issues within the Grey Cloud Slough meander. This is the only alternative that does not result in recreational boating navigability. The large culvert alternative is nearly double the POPCC of the small culvert alternative, but provides the recreational navigability and a more complete restoration of the channel. While the large culvert provide navigability under normal spring flood conditions travel would be somewhat difficult due to high velocities, which are over 7 feet per second during the 2 year flood (38,500 cfs). The culvert would not be traversable during flood conditions above approximately 65,000 cfs. During the higher flows both culvert alternatives present a safety concern to recreational boats. Neither of the culvert alternatives envisions a natural substrate.

The bridge alternative is the option that is most consistent with all of the design goals established by the TAC. The bridge alternative is superior to both the culvert alternatives in ecological restoration, fish

DRAFT

passage, water quality benefits, and recreational navigability. The only area where the bridge is less desirable than the culvert alternatives is the greater cost.

Based upon our analysis the bridge alternative is recommended for restoring Grey Cloud Slough with the following additional recommendations:

- Recommend proceeding with final geotechnical analysis and updating preliminary engineering plans and cost estimates to account for any changes in assumptions, regardless of the alternative chosen;
- Recommend posting an advisory speed of 25 mph along the two curves;
- Recommend consulting with the County regarding maintenance of the bridge and whether the bottomless culvert option would be more agreeable if the bridge alternative is pursued;
- Recommend discussion among TAC members whether the incremental increase in cost between the large culvert and bridge alternative is desired.

The decision relative to the preferred alternative essentially comes down to the importance of the recreational navigability and increased restoration of the channel and how that relates to the increase in cost.

DRAFT

8 References

Chuck Hubbard, Braun Intertec. December 21, 2011. Preliminary Geotechnical Assessment Grey Cloud Island Drive Bridge Concept.

FEMA. February 3, 2010. Washington County, MN Flood Insurance Study.

Mississippi River Team. July 21, 2010. Lower Pool 2 Restoration Project.

U.S. Army Corps of Engineers. 2003. Upper Mississippi River System Flow Frequency Study, Appendix B.

WEST Consultants, Inc. March 2011. Mississippi River (Pool 2) 2-D ADH Model Development.

DRAFT

9 List of Appendices

9.1 Appendix A: Braun Intertec Preliminary Geotechnical Assessment

9.2 Appendix B: Soil Boring Logs

9.3 Appendix C: HEC-RAS Results

9.4 Appendix D: Sediment Transport Results

DRAFT

Appendix A

December 21, 2011

Project SP-11-07799

Mr. Mike Lawrence, PE
Houston Engineering, Inc.
6901 East Fish Lake Road, Suite 140
Maple Grove, MN 55369

Re: Preliminary Geotechnical Assessment
Grey Cloud Island Drive Bridge Concept
Grey Cloud Island Drive S. (County Road 75)
Grey Cloud Township, Minnesota

Dear Mr. Lawrence:

We prepared this letter to help Houston Engineering, Inc, develop preliminary planning and budgetary information for a possible bridge along Grey Cloud Island Drive South (County Road 75), approximately 1/4 mile south of Grey Cloud Trail South, where the road currently crosses a tributary to the Mississippi River on an earth embankment. Consideration is being given to replacing the embankment with a bridge to help regulate water levels on both sides of the road and lessen the impact of seasonal flooding.

Project Details

Plans for the bridge are not yet available. The attached aerial, however, shows a possible location for the bridge. Houston anticipates supporting the bridge on deep foundations, likely driven piles, and cutting the abutment slopes back at a gradient as steep as 2:1 (horizontal:vertical).

Available Geotechnical Information

In March of 2011, our firm drilled four penetration test borings in the vicinity of the proposed bridge. Those borings are denoted ST-1, ST-2, ST-3 and ST-4 on the attached aerial. Logs of the borings remain in draft form pending laboratory testing and further review and are therefore not attached.

Below the existing pavement, the borings encountered mixed but generally sandy fill to depths that, in the vicinity of the proposed bridge (Borings ST-2 and ST-3), ranged from approximately 14 to 31 feet. The uniformity and consistency of the fill varied widely. At Boring ST-3, in particular, our hollow-stem auger dropped between depths of approximately 6 and 14 feet, suggesting that a large void or a series of voids were present within the fill at that location; penetration resistance values as low as 1 blow per foot were also recorded in debris-laden (mainly wood) portions of the fill, and in some cases the weight of the sampling hammer alone was sufficient to cause 1 foot of penetration.

The fill was underlain with alluvial soils consisting mainly of sand but, at Boring ST-3, with organic silt as well. The alluvial soils were generally very loose to loose. The alluvial soils continued to the 21-foot termination depth of Boring ST-2, but were penetrated by Boring ST-3 at about the 40-foot depth, below which very dense material judged to be glacial outwash or weathered limestone bedrock was encountered.

Design Considerations

While materials capable of contributing to foundation support were encountered at relatively shallow depths, materials in which deep foundations could likely be terminated look to be on the order of 40 feet or more below existing grades. It therefore appears that deep foundations will indeed be required for bridge support. It would not be unreasonable, in our opinion, to anticipate that working pile capacities on the order of 100 tons or more could be achieved.

While driven piles might normally be the foundation of choice for this application, given the depth to which Boring ST-3 in particular was advanced prior to penetrating material that appeared potentially capable of supporting bridge foundations, driving tip protection will likely be required and pile sweep or damage would need to be considered. Cast-in-place concrete piers could also be considered in this case to provide a more reliable means of penetrating obstructions, but casing, obstruction removal and dewatering could make this alternative as difficult and more time consuming to implement.

Most importantly, we do not recommend presuming that piles or piers will be limited to depths on the order of 40 feet. Soils less dense or stiff than those encountered within the depths explored could be present that ultimately require deeper embedment. Confirming that the material encountered at the termination depth of Boring ST-3 was in fact glacial outwash or weathered limestone bedrock might also influence embedment and the type of foundation selected.

With regard to cut slopes that would be extended down and away from the bridge abutments and into the water, gradients in the range of 2:1 to 4:1 (horizontal:vertical) are not unreasonable; armoring to protect the slopes from wave-, ice- and flood- induced erosion would likely provide adequate long-term or steady-state stability. In addition to any hydraulic design requirements that would require flatter slopes, the predominant granular soils penetrated by our borings could support a 2:1 gradient. Debris, voids and other inconsistencies in soil composition and consistency, however, might ultimately warrant significant ground improvement efforts to maintain a gradient that steep, or might warrant flatter slopes.

Further Exploration and Evaluation

While it appears that preliminary plans can include provisions for supporting the bridge on foundations no less than 40 feet deep and cutting abutment slopes at a gradient as steep as 2:1 (horizontal:vertical), such plans should be qualified with recommendations for further exploration and evaluation of subsurface conditions in the area, specifically at the abutment locations. To that end, we recommend at least one boring at each abutment location that is extended to a depth no less than 75 feet, with penetration testing on a continuous basis through the fill, and at a half-flight (2 1/2-foot) interval below the fill. Coring should also be anticipated to verify if suspected bedrock is in fact in-place bedrock.

Laboratory testing to help classify the materials encountered and measure or estimate their strength for foundation support and slope stability purposes should also be performed.

In the absence of a formal proposal, which we can provide if needed, we estimate the cost of such an evaluation to be on the order of \$12,000.

Remarks

In performing its services, Braun Interotec used that degree of care and skill ordinarily exercised under similar circumstances by reputable members of its profession currently practicing in the same locality. No warranty, express or implied, is made.

If you have any questions about this Addendum, please contact Charles Hubbard at 612.221.2501.

Sincerely,

BRAUN INTERTEC CORPORATION

Professional Certification:

I hereby certify that this plan, specification or report was prepared by me or under my direct supervision and that I am a duly Licensed Professional Engineer under the laws of the State of Minnesota.

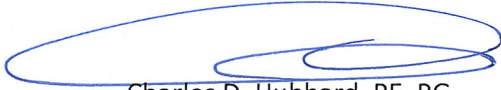

Charles D. Hubbard, PE, PG
Principal Engineer/Geologist
License Number: 21153



Matthew P. Ruble, PE
Principal Engineer

Attachments:

Aerial with Bridge and Boring Locations

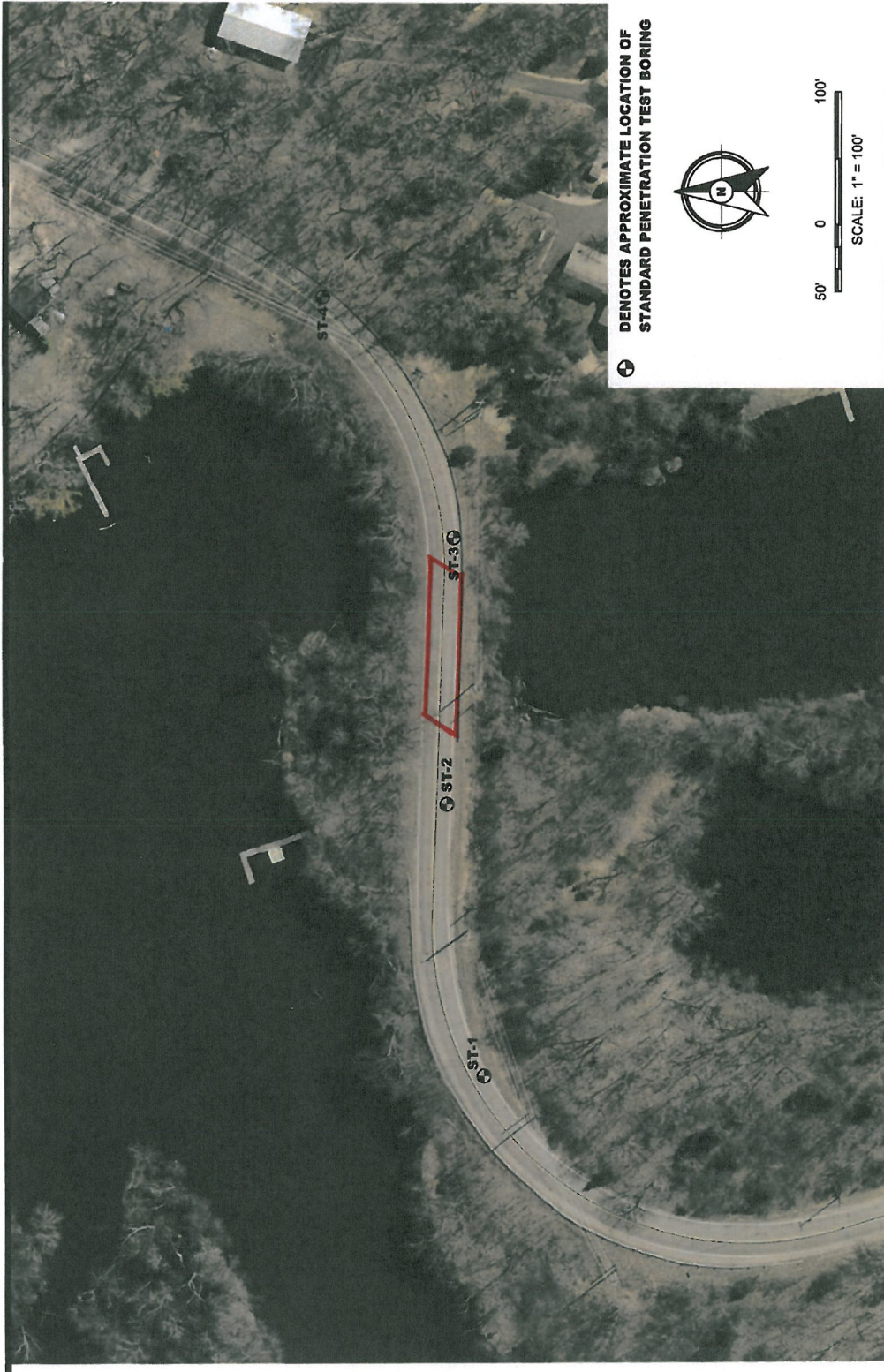

Project No: SP1101226A
 Drawing No: SP1101226A
 Scale: 1" = 100'
 Drawn By: BJB
 Date Drawn: 4/1/11
 Checked By: CDT
 Last Modified: 4/1/11

Sheet: _____ of _____
 Fig: _____

SOIL BORING LOCATION SKETCH
EMBANKMENT CHARACTERIZATION
GREY CLOUD ISLAND DRIVE SOUTH FLOOD PROTECTION
COUNTY ROAD 75
GREY CLOUD ISLAND, MINNESOTA

BRAUN
INTERTEC
 11001 Hemphshire Avenue So.
 Minneapolis, MN 55438
 PH. (952) 995-2000
 FAX (952) 995-2020

DRAFT

Appendix B

(See Descriptive Terminology sheet for explanation of abbreviations)

LOG OF BORING N:\GINT\PROJECTS\STPAUL\2011\01226A.GPJ BRAUN_V8_CURRENT.GDT 10/26/11 15:02

Braun Project SP-11-01226A Geotechnical Evaluation Grey Cloud Island Drive S Flood Protection County Road 75 Grey Cloud Island, Minnesota			BORING: ST-1		
DRILLER: J. Chermak			METHOD: 3 1/4" HSA, Autohammer		
DATE: 3/25/11			SCALE: 1" = 4'		
Depth feet	Symbol	Description of Materials (Soil- ASTM D2488 or D2487, Rock-USACE EM1110-1-2908)	BPF	WL	Tests or Notes
0.0					
0.5	PAV	6" of bituminous			
1.3	FILL	FILL: 9" of aggregate base.			
	FILL	FILL: Poorly Graded Sand with Silt and Gravel, fine- to coarse-grained, dark brown, moist.			
			7*		*Poor recovery from 2 to 5 feet
			22		P200 = %, full gradation attached
			18		
9.0	FILL	Presumed -			No recovery from 9 to 11 feet
			13		
11.0	SC-SM	SILTY CLAYEY SAND, fine-grained, brown, waterbearing, very loose. (Alluvium)		▽	P200 = %, full gradation attached
14.0	SP	POORLY GRADED SAND, fine- to medium-grained, brown, waterbearing, very loose. (Alluvium)			
			2		
			2		P200 = %, full gradation attached
19.0	SP-SM	POORLY GRADED SAND with SILT, fine-grained, brown, waterbearing, very loose. (Alluvium)			
			2		
21.0		END OF BORING.			An open triangle in the water level (WL) column indicates the depth at which groundwater was observed while drilling. Groundwater levels fluctuate.
		Water observed at 12 1/2 feet while drilling.			
		Water observed at 19 feet immediately after withdrawal of auger.			
		Water not observed to cave-in depth of 12 feet immediately after withdrawal of auger.			
		Boring then backfilled.			

Braun Project SP-11-01226A Geotechnical Evaluation Grey Cloud Island Drive S Flood Protection County Road 75 Grey Cloud Island, Minnesota			BORING: ST-2 LOCATION: See attached sketch.		
DRILLER: J. Chermak		METHOD: 3 1/4" HSA, Autohammer		DATE: 3/25/11	SCALE: 1" = 4'
Depth feet	Symbol	Description of Materials (Soil- ASTM D2488 or D2487, Rock-USACE EM1110-1-2908)	BPF	WL	Tests or Notes
0.0					
0.5	PAV	6 1/4" of bituminous			
	FILL	FILL: 24" of aggregate base			
2.2					
3.0	FILL	FILL: Silty Sand, fine-grained, yellowish-brown, moist.	25		
	FILL	FILL: Poorly Graded Sand with Silt and Gravel, fine- to medium-grained, dark brown, moist.	25		P200 = %, full gradation attached
			22		
9.0					
	FILL	FILL: Silty Sand, fine-grained, dark brown, moist, loose. (Glacial Outwash)	8		
			2	▽	
14.0					
	SC-SM	SILTY CLAYEY SAND, fine-grained, brown, waterbearing, very loose. (Glacial Outwash)	*		* 1 blow produced 18" of penetration
17.0					
	SM	SILTY SAND, medium- to coarse-grained, brown, waterbearing, loose. (Glacial Outwash)	7		P200 = %, full gradation attached
21.0			7		
		END OF BORING.			
		Water observed at 12 1/2 feet while drilling.			
		Water observed at 19 feet immediately after withdrawal of auger.			
		Water not observed to cave-in depth of 12 feet immediately after withdrawal of auger.			
		Boring then backfilled.			

(See Descriptive Terminology sheet for explanation of abbreviations)

LOG OF BORING N:\GINT\PROJECTS\STPAUL\2011\01226A.GPJ BRAUN_V8_CURRENT.GDT 10/26/11 15:02

(See Descriptive Terminology sheet for explanation of abbreviations)

LOG OF BORING N:\GINT\PROJECTS\STPAUL\2011\01226A.GPJ BRAUN_V8_CURRENT.GDT 10/26/11 11:15:02

Braun Project SP-11-01226A Geotechnical Evaluation Grey Cloud Island Drive S Flood Protection County Road 75 Grey Cloud Island, Minnesota			BORING: ST-3		
DRILLER: J. Chermak			METHOD: 3 1/4" HSA, Autohammer		
DATE: 3/24/11			SCALE: 1" = 4'		
Depth feet	Symbol	Description of Materials (Soil- ASTM D2488 or D2487, Rock-USACE EM1110-1-2908)	BPF	WL	Tests or Notes
0.0					
0.5	PAV	5 1/2" of bituminous			
	FILL	FILL: 36 1/2" of aggregate base			
3.5	FILL	FILL: Poorly Graded Sand with Silt and Gravel, fine- to medium-grained, black and brown, moist.	36		
6.0	FILL	VOID	37		P200 = %, full gradation attached
			WH		Auger and sampler dropped 7 feet.
			WH		
14.0	FILL	Many pieces of wood and Gravel.	1	▽	Poor recovery from 14 to 25 feet
			1		
19.0	FILL	FILL: Poorly Graded Sand with Silt and Gravel, fine- to medium-grained, many pieces of wood, brown, waterbearing.	8		P200 = %, full gradation attached
			11		Refusal at 21 feet, offset 15 feet W and redrilled to 25 feet..
24.0	FILL	Wood fragments			
25.0	FILL	FILL: Poorly Graded Sand with Gravel, fine- to medium-grained, brown, waterbearing.	*		* 50 blows for 6" (set)
26.5	FILL	FILL: Poorly-Graded Gravel with Sand, fine-grained, coarse-grained, with limestone pieces, brown, waterbearing.	30		
29.0	FILL	FILL: Poorly Graded Sand, medium-grained, with pieces of wood, lenses of Lean Clay, brown and gray, waterbearing, loose.	6		
31.0	OL	ORGANIC SILT with SAND, pieces of wood, black, wet, soft.			

(See Descriptive Terminology sheet for explanation of abbreviations)

LOG OF BORING N:\GINT\PROJECTS\STPAUL\2011\01226A.GPJ BRAUN_V8_CURRENT.GDT 10/26/11 15:02

Braun Project SP-11-01226A Geotechnical Evaluation Grey Cloud Island Drive S Flood Protection County Road 75 Grey Cloud Island, Minnesota			BORING: ST-3 (cont.) LOCATION: See attached sketch.		
DRILLER: J. Chermak	METHOD: 3 1/4" HSA, Autohammer	DATE: 3/24/11	SCALE: 1" = 4'		
Depth feet	Symbol	Description of Materials (Soil- ASTM D2488 or D2487, Rock-USACE EM1110-1-2908)	BPF	WL	Tests or Notes
32.0					
34.0		ORGANIC SILT with SAND, pieces of wood, black, wet, soft. <i>(continued)</i>	2		OC =
	SP	POORLY GRADED SAND, medium- to coarse-grained, with lenses of Lean Clay, brown, waterbearing, loose. (Alluvium)	7		P200 = %, full gradation attached
			12		
40.0					
41.0	GP	POORLY GRADED GRAVEL, consisting mainly of limestone with Sand, brownish-yellow, waterbearing, very dense. (Glacial Outwash or Weathered Bedrock)	*		* 50 blows for 1/8"
		END OF BORING.			
		Water observed at 15 feet while drilling.			
		Water observed at 20 feet immediately after withdrawal of auger.			
		Boring then grouted with 7 to 8 bags of bentonite and filled with 2 truck loads of sand backfill.			

(See Descriptive Terminology sheet for explanation of abbreviations)

LOG OF BORING N:\GINT\PROJECTS\STPAUL\2011\01226A.GPJ BRAUN_V8_CURRENT.GDT 10/26/11 15:02

Braun Project SP-11-01226A Geotechnical Evaluation Grey Cloud Island Drive S Flood Protection County Road 75 Grey Cloud Island, Minnesota			BORING: ST-4		
DRILLER: J. Chermak			METHOD: 3 1/4" HSA, Autohammer		
DATE: 3/25/11			SCALE: 1" = 4'		
Depth feet	Symbol	Description of Materials (Soil- ASTM D2488 or D2487, Rock-USACE EM1110-1-2908)	BPF	WL	Tests or Notes
0.0					
0.5	PAV	5 3/4" of bituminous			
1.2	FILL	FILL: 8" of aggregate base			
	FILL	FILL: Poorly Graded Sand with Silt and Gravel, fine- to medium-grained, with pieces of bituminous, inclusions of Lean Clay, brown and black, moist.	17		Sieve/hydro
6.0			46*		*No recovery
	FILL	FILL: Silty Sand, fine- to medium-grained, dark brown, moist.	7		
9.0					
	SP	POORLY GRADED SAND, fine-grained, brown, moist, very loose. (Alluvium)	4		
11.0					
	SP	POORLY GRADED SAND, fine- to medium-grained, with a trace of Silt, brown, waterbearing, very loose. (Alluvium)	4	▽	Sieve/hydro
			2		
17.0					
	GP	POORLY GRADED GRAVEL, consisting mainly of limestone with Sand, yellowish-brown, waterbearing, medium dense to dense. (Glacial Outwash/ Weathered Bedrock)	14		
21.0			39		
		END OF BORING. Water observed at 12 1/2 feet while drilling. Water observed at 15 feet immediately after withdrawal of auger. Water not observed to cave-in depth of 11 1/2 feet immediately after withdrawal of auger. Boring then backfilled.			

DRAFT

Appendix C

HEC-RAS Plan: Existing River: Grey Cloud Reach: Channel

Reach	River Sta	Profile	Q Total (cfs)	Min Ch El (ft)	W.S. Elev (ft)	Crit W.S. (ft)	E.G. Elev (ft)	E.G. Slope (ft/ft)	Vel Chnl (ft/s)	Flow Area (sq ft)	Top Width (ft)	Froude # Chl
Channel	15516.50	2 Year	0.45	681.84	689.61		689.61	0.000000	0.00	1227.86	247.83	0.00
Channel	15516.50	5 Year	0.56	681.84	692.26		692.26	0.000000	0.00	1905.33	266.25	0.00
Channel	15516.50	10 Year	0.56	681.84	694.33		694.33	0.000000	0.00	2492.23	314.17	0.00
Channel	15516.50	50 Year	0.53	681.84	698.57		698.57	0.000000	0.00	4488.51	551.84	0.00
Channel	15516.50	100 Year	0.51	681.84	700.10		700.10	0.000000	0.00	5334.97	555.32	0.00
Channel	15516.50	500 Year	3522.14	681.84	703.63		703.64	0.000006	0.65	7309.96	564.34	0.03
Channel	15516.50	5th Percentile	0.03	681.84	686.57		686.57	0.000000	0.00	496.83	231.58	0.00
Channel	15516.50	Median Flow	0.16	681.84	686.73		686.73	0.000000	0.00	533.11	232.43	0.00
Channel	15462.15	2 Year	0.45	684.38	689.61		689.61	0.000000	0.00	846.18	204.42	0.00
Channel	15462.15	5 Year	0.56	684.38	692.26		692.26	0.000000	0.00	1397.38	211.82	0.00
Channel	15462.15	10 Year	0.56	684.38	694.33		694.33	0.000000	0.00	1846.18	230.60	0.00
Channel	15462.15	50 Year	0.53	684.38	698.57		698.57	0.000000	0.00	3542.26	522.32	0.00
Channel	15462.15	100 Year	0.51	684.38	700.10		700.10	0.000000	0.00	4342.81	524.79	0.00
Channel	15462.15	500 Year	3522.14	684.38	703.63		703.64	0.000010	0.80	6206.04	532.32	0.03
Channel	15462.15	5th Percentile	0.03	684.38	686.57		686.57	0.000000	0.00	254.19	173.58	0.00
Channel	15462.15	Median Flow	0.16	684.38	686.73		686.73	0.000000	0.00	281.56	176.44	0.00
Channel	15403.78	2 Year	0.45	683.69	689.61		689.61	0.000000	0.00	732.90	152.03	0.00
Channel	15403.78	5 Year	0.56	683.69	692.26		692.26	0.000000	0.00	1148.25	161.79	0.00
Channel	15403.78	10 Year	0.56	683.69	694.33		694.33	0.000000	0.00	1495.36	186.74	0.00
Channel	15403.78	50 Year	0.53	683.69	698.57		698.57	0.000000	0.00	3082.18	474.26	0.00
Channel	15403.78	100 Year	0.51	683.69	700.10		700.10	0.000000	0.00	3818.39	486.52	0.00
Channel	15403.78	500 Year	3522.14	683.69	703.62		703.64	0.000014	0.98	5555.17	502.69	0.04
Channel	15403.78	5th Percentile	0.03	683.69	686.57		686.57	0.000000	0.00	285.05	142.74	0.00
Channel	15403.78	Median Flow	0.16	683.69	686.73		686.73	0.000000	0.00	307.44	143.59	0.00
Channel	14983.37	2 Year	0.45	681.30	689.61		689.61	0.000000	0.00	1095.79	240.34	0.00
Channel	14983.37	5 Year	0.56	681.30	692.26		692.26	0.000000	0.00	1921.26	371.88	0.00
Channel	14983.37	10 Year	0.56	681.30	694.33		694.33	0.000000	0.00	2729.37	415.72	0.00
Channel	14983.37	50 Year	0.53	681.30	698.57		698.57	0.000000	0.00	4670.27	478.74	0.00
Channel	14983.37	100 Year	0.51	681.30	700.10		700.10	0.000000	0.00	5405.78	483.31	0.00
Channel	14983.37	500 Year	3522.14	681.30	703.62		703.63	0.000008	0.79	7125.70	493.83	0.03
Channel	14983.37	5th Percentile	0.03	681.30	686.57		686.57	0.000000	0.00	544.12	133.47	0.00
Channel	14983.37	Median Flow	0.16	681.30	686.73		686.73	0.000000	0.00	565.06	134.33	0.00
Channel	14111.45	2 Year	0.45	674.60	689.61		689.61	0.000000	0.00	3094.36	499.86	0.00
Channel	14111.45	5 Year	0.56	674.60	692.26		692.26	0.000000	0.00	4532.42	568.54	0.00
Channel	14111.45	10 Year	0.56	674.60	694.33		694.33	0.000000	0.00	5768.56	626.00	0.00
Channel	14111.45	50 Year	0.53	674.60	698.57		698.57	0.000000	0.00	8596.56	702.61	0.00
Channel	14111.45	100 Year	0.51	674.60	700.10		700.10	0.000000	0.00	9688.67	726.49	0.00
Channel	14111.45	500 Year	3522.14	674.60	703.62		703.63	0.000002	0.41	12361.95	789.45	0.01
Channel	14111.45	5th Percentile	0.03	674.60	686.57		686.57	0.000000	0.00	1940.65	252.48	0.00
Channel	14111.45	Median Flow	0.16	674.60	686.73		686.73	0.000000	0.00	1980.36	255.33	0.00
Channel	14030.47	2 Year	0.45	676.20	689.61		689.61	0.000000	0.00	2087.89	309.38	0.00
Channel	14030.47	5 Year	0.56	676.20	692.26		692.26	0.000000	0.00	3128.37	484.61	0.00
Channel	14030.47	10 Year	0.56	676.20	694.33		694.33	0.000000	0.00	4268.12	612.09	0.00
Channel	14030.47	50 Year	0.53	676.20	698.57		698.57	0.000000	0.00	7114.37	732.25	0.00
Channel	14030.47	100 Year	0.51	676.20	700.10		700.10	0.000000	0.00	8257.15	761.95	0.00
Channel	14030.47	500 Year	3522.14	676.20	703.62		703.63	0.000003	0.52	11078.75	844.15	0.02
Channel	14030.47	5th Percentile	0.03	676.20	686.57		686.57	0.000000	0.00	1339.93	200.35	0.00
Channel	14030.47	Median Flow	0.16	676.20	686.73		686.73	0.000000	0.00	1371.36	201.56	0.00
Channel	13998.91	2 Year	0.45	676.80	689.61	676.93	689.61	0.000000	0.00	1633.90	250.37	0.00
Channel	13998.91	5 Year	0.56	676.80	692.26	676.94	692.26	0.000000	0.00	2365.11	344.28	0.00
Channel	13998.91	10 Year	0.56	676.80	694.33	676.94	694.33	0.000000	0.00	3148.66	433.82	0.00
Channel	13998.91	50 Year	0.53	676.80	698.57	676.94	698.57	0.000000	0.00	5223.88	631.57	0.00
Channel	13998.91	100 Year	0.51	676.80	700.10	676.93	700.10	0.000000	0.00	6229.87	679.79	0.00
Channel	13998.91	500 Year	3522.14	676.80	703.62	681.98	703.63	0.000005	0.65	8761.21	758.28	0.02
Channel	13998.91	5th Percentile	0.03	676.80	686.57	676.84	686.57	0.000000	0.00	1020.84	170.04	0.00
Channel	13998.91	Median Flow	0.16	676.80	686.73	676.88	686.73	0.000000	0.00	1047.54	171.46	0.00
Channel	13915.22		Culvert									
Channel	13839.69	2 Year	0.45	679.00	687.27		687.27	0.000000	0.00	879.44	186.78	0.00
Channel	13839.69	5 Year	0.56	679.00	688.57		688.57	0.000000	0.00	1126.81	193.71	0.00
Channel	13839.69	10 Year	0.56	679.00	690.66		690.66	0.000000	0.00	1544.94	212.87	0.00
Channel	13839.69	50 Year	0.53	679.00	695.37		695.37	0.000000	0.00	2903.41	396.45	0.00
Channel	13839.69	100 Year	0.51	679.00	697.07		697.07	0.000000	0.00	3647.00	450.89	0.00
Channel	13839.69	500 Year	3522.14	679.00	701.25		701.26	0.000011	0.85	5899.23	616.69	0.03
Channel	13839.69	5th Percentile	0.03	679.00	686.56		686.56	0.000000	0.00	748.89	180.28	0.00
Channel	13839.69	Median Flow	0.16	679.00	686.43		686.43	0.000000	0.00	725.34	177.97	0.00
Channel	13775.91	2 Year	0.45	677.10	687.27		687.27	0.000000	0.00	1131.06	179.23	0.00
Channel	13775.91	5 Year	0.56	677.10	688.57		688.57	0.000000	0.00	1371.50	191.55	0.00
Channel	13775.91	10 Year	0.56	677.10	690.66		690.66	0.000000	0.00	1791.87	209.02	0.00
Channel	13775.91	50 Year	0.53	677.10	695.37		695.37	0.000000	0.00	3244.52	439.47	0.00
Channel	13775.91	100 Year	0.51	677.10	697.07		697.07	0.000000	0.00	3998.74	444.76	0.00
Channel	13775.91	500 Year	3522.14	677.10	701.25		701.26	0.000009	0.81	5882.09	459.38	0.03
Channel	13775.91	5th Percentile	0.03	677.10	686.56		686.56	0.000000	0.00	1006.41	172.53	0.00

HEC-RAS Plan: Existing River: Grey Cloud Reach: Channel (Continued)

Reach	River Sta	Profile	Q Total (cfs)	Min Ch El (ft)	W.S. Elev (ft)	Crit W.S. (ft)	E.G. Elev (ft)	E.G. Slope (ft/ft)	Vel Chnl (ft/s)	Flow Area (sq ft)	Top Width (ft)	Froude # Chl
Channel	13775.91	Median Flow	0.16	677.10	686.43		686.43	0.000000	0.00	983.81	171.29	0.00
Channel	13087.15	2 Year	0.45	677.20	687.27		687.27	0.000000	0.00	878.50	138.83	0.00
Channel	13087.15	5 Year	0.56	677.20	688.57		688.57	0.000000	0.00	1062.89	144.28	0.00
Channel	13087.15	10 Year	0.56	677.20	690.66		690.66	0.000000	0.00	1370.12	149.64	0.00
Channel	13087.15	50 Year	0.53	677.20	695.37		695.37	0.000000	0.00	2420.74	353.31	0.00
Channel	13087.15	100 Year	0.51	677.20	697.07		697.07	0.000000	0.00	3073.02	410.96	0.00
Channel	13087.15	500 Year	3522.14	677.20	701.23		701.25	0.000015	1.04	4888.21	443.09	0.04
Channel	13087.15	5th Percentile	0.03	677.20	686.56		686.56	0.000000	0.00	781.59	134.67	0.00
Channel	13087.15	Median Flow	0.16	677.20	686.43		686.43	0.000000	0.00	763.94	133.90	0.00
Channel	11895.96	2 Year	0.45	678.10	687.27		687.27	0.000000	0.00	815.52	136.36	0.00
Channel	11895.96	5 Year	0.56	678.10	688.57		688.57	0.000000	0.00	997.34	142.34	0.00
Channel	11895.96	10 Year	0.56	678.10	690.66		690.66	0.000000	0.00	1372.52	256.86	0.00
Channel	11895.96	50 Year	0.53	678.10	695.37		695.37	0.000000	0.00	3055.15	391.35	0.00
Channel	11895.96	100 Year	0.51	678.10	697.07		697.07	0.000000	0.00	3725.18	394.26	0.00
Channel	11895.96	500 Year	3522.14	678.10	701.22		701.23	0.000013	0.96	5374.12	401.35	0.04
Channel	11895.96	5th Percentile	0.03	678.10	686.56		686.56	0.000000	0.00	720.61	131.47	0.00
Channel	11895.96	Median Flow	0.16	678.10	686.43		686.43	0.000000	0.00	703.39	130.57	0.00
Channel	10838.82	2 Year	0.45	674.40	687.27	674.53	687.27	0.000000	0.00	936.50	124.85	0.00
Channel	10838.82	5 Year	0.56	674.40	688.57	674.54	688.57	0.000000	0.00	1102.74	277.53	0.00
Channel	10838.82	10 Year	0.56	674.40	690.66	674.55	690.66	0.000000	0.00	1854.55	384.31	0.00
Channel	10838.82	50 Year	0.53	674.40	695.37	674.54	695.37	0.000000	0.00	3697.08	399.20	0.00
Channel	10838.82	100 Year	0.51	674.40	697.07	674.54	697.07	0.000000	0.00	4382.66	404.64	0.00
Channel	10838.82	500 Year	3522.14	674.40	701.21	681.30	701.22	0.000010	0.89	6083.09	417.82	0.03
Channel	10838.82	5th Percentile	0.03	674.40	686.56	674.44	686.56	0.000000	0.00	849.35	121.12	0.00
Channel	10838.82	Median Flow	0.16	674.40	686.43	674.49	686.43	0.000000	0.00	833.47	120.43	0.00
Channel	9688.304	2 Year	0.45	675.30	687.27	675.43	687.27	0.000000	0.00	1046.75	133.25	0.00
Channel	9688.304	5 Year	0.56	675.30	688.57	675.44	688.57	0.000000	0.00	1223.54	296.03	0.00
Channel	9688.304	10 Year	0.56	675.30	690.66	675.44	690.66	0.000000	0.00	2017.08	387.67	0.00
Channel	9688.304	50 Year	0.53	675.30	695.37	675.44	695.37	0.000000	0.00	3862.11	396.91	0.00
Channel	9688.304	100 Year	0.51	675.30	697.07	675.44	697.07	0.000000	0.00	4542.00	400.26	0.00
Channel	9688.304	500 Year	3522.14	675.30	701.20	680.98	701.21	0.000009	0.85	6209.55	408.37	0.03
Channel	9688.304	5th Percentile	0.03	675.30	686.56	675.34	686.56	0.000000	0.00	953.67	129.45	0.00
Channel	9688.304	Median Flow	0.16	675.30	686.43	675.38	686.43	0.000000	0.00	936.69	128.74	0.00
Channel	8258.395	2 Year	0.45	677.10	687.27		687.27	0.000000	0.00	795.12	110.73	0.00
Channel	8258.395	5 Year	0.56	677.10	688.57		688.57	0.000000	0.00	1001.88	246.17	0.00
Channel	8258.395	10 Year	0.56	677.10	690.66		690.66	0.000000	0.00	1742.05	439.73	0.00
Channel	8258.395	50 Year	0.53	677.10	695.37		695.37	0.000000	0.00	3833.39	449.40	0.00
Channel	8258.395	100 Year	0.51	677.10	697.07		697.07	0.000000	0.00	4602.89	452.85	0.00
Channel	8258.395	500 Year	3522.14	677.10	701.18		701.19	0.000011	0.90	6481.38	461.16	0.03
Channel	8258.395	5th Percentile	0.03	677.10	686.56		686.56	0.000000	0.00	717.83	107.41	0.00
Channel	8258.395	Median Flow	0.16	677.10	686.43		686.43	0.000000	0.00	703.74	106.79	0.00
Channel	7389.075	2 Year	0.45	678.70	687.27		687.27	0.000000	0.00	2255.55	438.05	0.00
Channel	7389.075	5 Year	0.56	678.70	688.57		688.57	0.000000	0.00	2826.66	442.20	0.00
Channel	7389.075	10 Year	0.56	678.70	690.66		690.66	0.000000	0.00	3758.71	447.90	0.00
Channel	7389.075	50 Year	0.53	678.70	695.37		695.37	0.000000	0.00	5898.73	461.94	0.00
Channel	7389.075	100 Year	0.51	678.70	697.07		697.07	0.000000	0.00	6690.86	466.83	0.00
Channel	7389.075	500 Year	3522.14	678.70	701.18		701.19	0.000003	0.42	8633.99	478.62	0.02
Channel	7389.075	5th Percentile	0.03	678.70	686.56		686.56	0.000000	0.00	1946.04	435.43	0.00
Channel	7389.075	Median Flow	0.16	678.70	686.43		686.43	0.000000	0.00	1888.83	434.95	0.00
Channel	5532.148	2 Year	0.45	679.90	687.27	679.97	687.27	0.000000	0.00	813.45	245.65	0.00
Channel	5532.148	5 Year	0.56	679.90	688.57	679.98	688.57	0.000000	0.00	1421.45	554.56	0.00
Channel	5532.148	10 Year	0.56	679.90	690.66	679.98	690.66	0.000000	0.00	2596.76	568.33	0.00
Channel	5532.148	50 Year	0.53	679.90	695.37	679.98	695.37	0.000000	0.00	5349.37	601.72	0.00
Channel	5532.148	100 Year	0.51	679.90	697.07	679.98	697.07	0.000000	0.00	6385.82	613.43	0.00
Channel	5532.148	500 Year	3522.14	679.90	701.18	684.33	701.18	0.000006	0.63	8957.05	639.70	0.03
Channel	5532.148	5th Percentile	0.03	679.90	686.56	679.93	686.56	0.000000	0.00	694.80	165.94	0.00
Channel	5532.148	Median Flow	0.16	679.90	686.43	679.95	686.43	0.000000	0.00	673.02	165.40	0.00
Channel	3522.239	2 Year	0.45	679.20	687.27		687.27	0.000000	0.00	1147.48	702.17	0.00
Channel	3522.239	5 Year	0.56	679.20	688.57		688.57	0.000000	0.00	2138.32	771.60	0.00
Channel	3522.239	10 Year	0.56	679.20	690.66		690.66	0.000000	0.00	3759.76	776.27	0.00
Channel	3522.239	50 Year	0.53	679.20	695.37		695.37	0.000000	0.00	7443.06	790.33	0.00
Channel	3522.239	100 Year	0.51	679.20	697.07		697.07	0.000000	0.00	8794.80	794.60	0.00
Channel	3522.239	500 Year	3522.14	679.20	701.17		701.17	0.000003	0.43	12071.14	804.86	0.02
Channel	3522.239	5th Percentile	0.03	679.20	686.56		686.56	0.000000	0.00	813.26	279.04	0.00
Channel	3522.239	Median Flow	0.16	679.20	686.43		686.43	0.000000	0.00	776.82	275.42	0.00
Channel	1410.166	2 Year	0.45	683.30	687.27		687.27	0.000000	0.00	1256.44	516.32	0.00
Channel	1410.166	5 Year	0.56	683.30	688.57		688.57	0.000000	0.00	2112.50	701.25	0.00
Channel	1410.166	10 Year	0.56	683.30	690.66		690.66	0.000000	0.00	3586.44	705.99	0.00
Channel	1410.166	50 Year	0.53	683.30	695.37		695.37	0.000000	0.00	6929.70	715.51	0.00
Channel	1410.166	100 Year	0.51	683.30	697.07		697.07	0.000000	0.00	8153.07	718.90	0.00
Channel	1410.166	500 Year	3522.14	683.30	701.16		701.17	0.000003	0.41	11111.41	727.57	0.02
Channel	1410.166	5th Percentile	0.03	683.30	686.56		686.56	0.000000	0.00	962.98	345.46	0.00

HEC-RAS Plan: Existing River: Grey Cloud Reach: Channel (Continued)

Reach	River Sta	Profile	Q Total (cfs)	Min Ch El (ft)	W.S. Elev (ft)	Crit W.S. (ft)	E.G. Elev (ft)	E.G. Slope (ft/ft)	Vel Chnl (ft/s)	Flow Area (sq ft)	Top Width (ft)	Froude # Chl
Channel	1410.166	Median Flow	0.16	683.30	686.43		686.43	0.000000	0.00	918.13	336.80	0.00
Channel	415.9752	2 Year	0.45	680.80	687.27		687.27	0.000000	0.00	2231.19	556.38	0.00
Channel	415.9752	5 Year	0.56	680.80	688.57		688.57	0.000000	0.00	3140.83	874.13	0.00
Channel	415.9752	10 Year	0.56	680.80	690.66		690.66	0.000000	0.00	4981.59	882.95	0.00
Channel	415.9752	50 Year	0.53	680.80	695.37		695.37	0.000000	0.00	9207.38	932.78	0.00
Channel	415.9752	100 Year	0.51	680.80	697.07		697.07	0.000000	0.00	10835.58	966.88	0.00
Channel	415.9752	500 Year	3522.14	680.80	701.16		701.16	0.000001	0.30	14852.97	997.78	0.01
Channel	415.9752	5th Percentile	0.03	680.80	686.56		686.56	0.000000	0.00	1844.35	535.34	0.00
Channel	415.9752	Median Flow	0.16	680.80	686.43		686.43	0.000000	0.00	1774.22	531.43	0.00

HEC-RAS Plan: culvert_small River: Grey Cloud Reach: Channel

Reach	River Sta	Profile	Q Total (cfs)	Min Ch El (ft)	W.S. Elev (ft)	Crit W.S. (ft)	E.G. Elev (ft)	E.G. Slope (ft/ft)	Vel Chnl (ft/s)	Flow Area (sq ft)	Top Width (ft)	Froude # Chl
Channel	15516.50	2 Year	301.13	681.84	689.59		689.59	0.000005	0.25	1221.28	247.68	0.02
Channel	15516.50	5 Year	460.45	681.84	692.22		692.22	0.000003	0.25	1894.71	265.88	0.02
Channel	15516.50	10 Year	510.01	681.84	694.30		694.30	0.000002	0.21	2482.24	312.49	0.01
Channel	15516.50	50 Year	477.64	681.84	698.55		698.55	0.000000	0.13	4476.65	551.79	0.01
Channel	15516.50	100 Year	464.90	681.84	700.09		700.09	0.000000	0.11	5326.70	555.29	0.01
Channel	15516.50	500 Year	3851.44	681.84	703.61		703.61	0.000007	0.71	7295.63	564.27	0.03
Channel	15516.50	5th Percentile	18.75	681.84	686.82		686.82	0.000000	0.03	553.29	232.91	0.00
Channel	15516.50	Median Flow	79.76	681.84	686.71		686.71	0.000006	0.15	528.93	232.33	0.02
Channel	15462.15	2 Year	301.13	684.38	689.59		689.59	0.000014	0.36	840.42	204.34	0.03
Channel	15462.15	5 Year	460.45	684.38	692.22		692.22	0.000006	0.34	1388.69	211.67	0.02
Channel	15462.15	10 Year	510.01	684.38	694.30		694.30	0.000003	0.28	1838.70	229.81	0.02
Channel	15462.15	50 Year	477.64	684.38	698.55		698.55	0.000001	0.17	3530.92	522.29	0.01
Channel	15462.15	100 Year	464.90	684.38	700.09		700.09	0.000000	0.14	4334.93	524.76	0.01
Channel	15462.15	500 Year	3851.44	684.38	703.60		703.61	0.000012	0.88	6192.14	532.26	0.04
Channel	15462.15	5th Percentile	18.75	684.38	686.82		686.82	0.000001	0.06	296.91	178.02	0.01
Channel	15462.15	Median Flow	79.76	684.38	686.71		686.71	0.000033	0.29	278.11	176.08	0.04
Channel	15403.78	2 Year	301.13	683.69	689.58		689.59	0.000015	0.42	728.38	151.94	0.03
Channel	15403.78	5 Year	460.45	683.69	692.22		692.22	0.000008	0.41	1141.39	161.62	0.03
Channel	15403.78	10 Year	510.01	683.69	694.30		694.30	0.000005	0.36	1489.11	185.64	0.02
Channel	15403.78	50 Year	477.64	683.69	698.55		698.55	0.000001	0.21	3071.73	474.11	0.01
Channel	15403.78	100 Year	464.90	683.69	700.09		700.09	0.000001	0.18	3810.99	486.28	0.01
Channel	15403.78	500 Year	3851.44	683.69	703.60		703.61	0.000017	1.07	5541.61	502.52	0.04
Channel	15403.78	5th Percentile	18.75	683.69	686.82		686.82	0.000001	0.06	319.89	144.02	0.01
Channel	15403.78	Median Flow	79.76	683.69	686.71		686.71	0.000018	0.26	304.45	143.47	0.03
Channel	14983.37	2 Year	301.13	681.30	689.58		689.58	0.000005	0.31	1088.03	239.56	0.02
Channel	14983.37	5 Year	460.45	681.30	692.22		692.22	0.000004	0.32	1905.00	371.16	0.02
Channel	14983.37	10 Year	510.01	681.30	694.30		694.30	0.000002	0.27	2715.22	415.12	0.01
Channel	14983.37	50 Year	477.64	681.30	698.55		698.55	0.000000	0.16	4659.73	478.68	0.01
Channel	14983.37	100 Year	464.90	681.30	700.09		700.09	0.000000	0.14	5398.43	483.26	0.01
Channel	14983.37	500 Year	3851.44	681.30	703.60		703.60	0.000010	0.87	7112.32	493.75	0.03
Channel	14983.37	5th Percentile	18.75	681.30	686.82		686.82	0.000000	0.03	576.69	134.80	0.00
Channel	14983.37	Median Flow	79.76	681.30	686.71		686.71	0.000002	0.14	562.06	134.20	0.01
Channel	14111.45	2 Year	301.13	674.60	689.58		689.58	0.000000	0.11	3078.20	499.11	0.01
Channel	14111.45	5 Year	460.45	674.60	692.22		692.22	0.000000	0.12	4507.57	567.43	0.01
Channel	14111.45	10 Year	510.01	674.60	694.30		694.30	0.000000	0.11	5747.28	625.71	0.01
Channel	14111.45	50 Year	477.64	674.60	698.55		698.55	0.000000	0.08	8581.08	702.27	0.00
Channel	14111.45	100 Year	464.90	674.60	700.09		700.09	0.000000	0.07	9677.63	726.24	0.00
Channel	14111.45	500 Year	3851.44	674.60	703.60		703.60	0.000002	0.45	12340.61	789.02	0.02
Channel	14111.45	5th Percentile	18.75	674.60	686.82		686.82	0.000000	0.01	2002.51	256.91	0.00
Channel	14111.45	Median Flow	79.76	674.60	686.71		686.71	0.000000	0.04	1974.66	254.92	0.00
Channel	14030.47	2 Year	301.13	676.20	689.58		689.58	0.000001	0.15	2077.82	308.36	0.01
Channel	14030.47	5 Year	460.45	676.20	692.22		692.22	0.000001	0.18	3107.06	482.61	0.01
Channel	14030.47	10 Year	510.01	676.20	694.30		694.30	0.000001	0.16	4247.19	610.28	0.01
Channel	14030.47	50 Year	477.64	676.20	698.55		698.55	0.000000	0.10	7098.20	731.78	0.00
Channel	14030.47	100 Year	464.90	676.20	700.09		700.09	0.000000	0.09	8245.53	761.64	0.00
Channel	14030.47	500 Year	3851.44	676.20	703.60		703.60	0.000004	0.57	11055.72	843.47	0.02
Channel	14030.47	5th Percentile	18.75	676.20	686.82		686.82	0.000000	0.01	1388.82	202.14	0.00
Channel	14030.47	Median Flow	79.76	676.20	686.71		686.71	0.000000	0.06	1366.85	201.40	0.00
Channel	13998.91	2 Year	301.13	676.80	689.58	679.08	689.58	0.000044	1.33	225.61	249.83	0.07
Channel	13998.91	5 Year	460.45	676.80	692.17	679.75	692.21	0.000055	1.69	272.76	340.52	0.08
Channel	13998.91	10 Year	510.01	676.80	694.25	679.94	694.29	0.000044	1.64	310.23	432.57	0.07
Channel	13998.91	50 Year	477.64	676.80	698.53	679.81	698.55	0.000018	1.23	387.17	629.32	0.05
Channel	13998.91	100 Year	464.90	676.80	700.07	679.76	700.09	0.000014	1.12	414.90	678.75	0.04
Channel	13998.91	500 Year	3851.44	676.80	703.59	688.27	703.60	0.000006	0.71	8740.21	757.53	0.03
Channel	13998.91	5th Percentile	18.75	676.80	686.82	677.34	686.82	0.000000	0.11	176.42	172.25	0.01
Channel	13998.91	Median Flow	79.76	676.80	686.71	677.86	686.71	0.000007	0.46	174.40	171.23	0.03
Channel	13915.22		Culvert									
Channel	13839.69	2 Year	301.13	679.00	687.35	681.68	687.42	0.000224	2.17	138.87	187.27	0.14
Channel	13839.69	5 Year	460.45	679.00	688.62	682.36	688.75	0.000315	2.84	161.86	193.91	0.17
Channel	13839.69	10 Year	510.01	679.00	690.67	682.55	690.77	0.000195	2.57	198.69	212.94	0.14
Channel	13839.69	50 Year	477.64	679.00	695.37	682.41	695.41	0.000052	1.69	283.32	396.59	0.07
Channel	13839.69	100 Year	464.90	679.00	697.07	682.38	697.11	0.000035	1.48	313.99	450.89	0.06
Channel	13839.69	500 Year	3851.44	679.00	701.25	690.87	701.26	0.000013	0.92	5902.70	616.85	0.04
Channel	13839.69	5th Percentile	18.75	679.00	686.81	679.86	686.81	0.000001	0.15	129.16	183.69	0.01
Channel	13839.69	Median Flow	79.76	679.00	686.44	680.49	686.45	0.000024	0.65	122.63	178.16	0.04
Channel	13775.91	2 Year	301.13	677.10	687.38		687.38	0.000004	0.26	1150.54	180.26	0.02
Channel	13775.91	5 Year	460.45	677.10	688.68		688.69	0.000006	0.33	1393.46	192.58	0.02
Channel	13775.91	10 Year	510.01	677.10	690.72		690.72	0.000003	0.29	1803.28	209.41	0.02
Channel	13775.91	50 Year	477.64	677.10	695.39		695.39	0.000001	0.17	3255.44	439.55	0.01
Channel	13775.91	100 Year	464.90	677.10	697.09		697.09	0.000000	0.15	4006.64	444.81	0.01
Channel	13775.91	500 Year	3851.44	677.10	701.25		701.26	0.000011	0.89	5884.64	459.41	0.03
Channel	13775.91	5th Percentile	18.75	677.10	686.81		686.81	0.000000	0.02	1048.48	174.82	0.00

HEC-RAS Plan: culvert_small River: Grey Cloud Reach: Channel (Continued)

Reach	River Sta	Profile	Q Total (cfs)	Min Ch El (ft)	W.S. Elev (ft)	Crit W.S. (ft)	E.G. Elev (ft)	E.G. Slope (ft/ft)	Vel Chnl (ft/s)	Flow Area (sq ft)	Top Width (ft)	Froude # Chl
Channel	13775.91	Median Flow	79.76	677.10	686.45		686.45	0.000000	0.08	986.21	171.43	0.01
Channel	13087.15	2 Year	301.13	677.20	687.38		687.38	0.000007	0.34	892.93	139.44	0.02
Channel	13087.15	5 Year	460.45	677.20	688.68		688.68	0.000009	0.43	1078.49	144.50	0.03
Channel	13087.15	10 Year	510.01	677.20	690.71		690.72	0.000005	0.37	1377.72	149.81	0.02
Channel	13087.15	50 Year	477.64	677.20	695.39		695.39	0.000001	0.23	2429.15	353.71	0.01
Channel	13087.15	100 Year	464.90	677.20	697.09		697.09	0.000001	0.19	3080.04	411.43	0.01
Channel	13087.15	500 Year	3851.44	677.20	701.24		701.25	0.000018	1.13	4889.37	443.09	0.04
Channel	13087.15	5th Percentile	18.75	677.20	686.81		686.81	0.000000	0.02	814.39	136.09	0.00
Channel	13087.15	Median Flow	79.76	677.20	686.45		686.45	0.000001	0.10	765.75	133.98	0.01
Channel	11895.96	2 Year	301.13	678.10	687.37		687.37	0.000009	0.36	828.35	137.01	0.03
Channel	11895.96	5 Year	460.45	678.10	688.66		688.67	0.000011	0.46	1010.94	142.50	0.03
Channel	11895.96	10 Year	510.01	678.10	690.71		690.71	0.000006	0.39	1383.86	258.37	0.02
Channel	11895.96	50 Year	477.64	678.10	695.39		695.39	0.000001	0.21	3064.02	391.39	0.01
Channel	11895.96	100 Year	464.90	678.10	697.09		697.09	0.000001	0.18	3731.66	394.29	0.01
Channel	11895.96	500 Year	3851.44	678.10	701.22		701.23	0.000015	1.05	5374.04	401.35	0.04
Channel	11895.96	5th Percentile	18.75	678.10	686.81		686.81	0.000000	0.02	752.66	133.14	0.00
Channel	11895.96	Median Flow	79.76	678.10	686.44		686.44	0.000001	0.11	705.02	130.65	0.01
Channel	10838.82	2 Year	301.13	674.40	687.36	676.41	687.36	0.000005	0.32	947.41	125.31	0.02
Channel	10838.82	5 Year	460.45	674.40	688.66	676.90	688.66	0.000007	0.41	1114.09	279.33	0.02
Channel	10838.82	10 Year	510.01	674.40	690.70	677.04	690.71	0.000004	0.35	1869.71	384.44	0.02
Channel	10838.82	50 Year	477.64	674.40	695.39	676.95	695.39	0.000001	0.19	3705.81	399.27	0.01
Channel	10838.82	100 Year	464.90	674.40	697.09	676.92	697.09	0.000000	0.16	4389.13	404.69	0.01
Channel	10838.82	500 Year	3851.44	674.40	701.21	681.59	701.22	0.000012	0.98	6082.19	417.81	0.04
Channel	10838.82	5th Percentile	18.75	674.40	686.81	674.98	686.81	0.000000	0.02	878.83	122.39	0.00
Channel	10838.82	Median Flow	79.76	674.40	686.44	675.45	686.44	0.000001	0.10	834.89	120.49	0.01
Channel	9688.304	2 Year	301.13	675.30	687.35	677.11	687.36	0.000004	0.28	1057.74	133.69	0.02
Channel	9688.304	5 Year	460.45	675.30	688.65	677.49	688.65	0.000006	0.37	1234.54	298.12	0.02
Channel	9688.304	10 Year	510.01	675.30	690.70	677.59	690.70	0.000003	0.32	2030.92	387.74	0.02
Channel	9688.304	50 Year	477.64	675.30	695.39	677.53	695.39	0.000001	0.18	3870.49	396.95	0.01
Channel	9688.304	100 Year	464.90	675.30	697.09	677.51	697.09	0.000000	0.15	4548.20	400.29	0.01
Channel	9688.304	500 Year	3851.44	675.30	701.19	681.23	701.20	0.000011	0.93	6207.83	408.36	0.04
Channel	9688.304	5th Percentile	18.75	675.30	686.81	675.88	686.81	0.000000	0.02	985.16	130.75	0.00
Channel	9688.304	Median Flow	79.76	675.30	686.44	676.31	686.44	0.000000	0.09	938.15	128.80	0.01
Channel	8258.395	2 Year	301.13	677.10	687.35		687.35	0.000008	0.37	803.31	111.08	0.02
Channel	8258.395	5 Year	460.45	677.10	688.64		688.64	0.000010	0.48	1018.65	252.51	0.03
Channel	8258.395	10 Year	510.01	677.10	690.69		690.70	0.000005	0.40	1754.85	439.80	0.02
Channel	8258.395	50 Year	477.64	677.10	695.39		695.39	0.000001	0.20	3842.38	449.44	0.01
Channel	8258.395	100 Year	464.90	677.10	697.09		697.09	0.000000	0.17	4609.64	452.88	0.01
Channel	8258.395	500 Year	3851.44	677.10	701.18		701.19	0.000013	0.99	6478.14	461.15	0.04
Channel	8258.395	5th Percentile	18.75	677.10	686.81		686.81	0.000000	0.03	743.96	108.54	0.00
Channel	8258.395	Median Flow	79.76	677.10	686.44		686.44	0.000001	0.11	704.87	106.84	0.01
Channel	7389.075	2 Year	301.13	678.70	687.35		687.35	0.000001	0.13	2287.46	438.32	0.01
Channel	7389.075	5 Year	460.45	678.70	688.64		688.64	0.000002	0.16	2856.14	442.37	0.01
Channel	7389.075	10 Year	510.01	678.70	690.69		690.69	0.000001	0.14	3771.75	447.98	0.01
Channel	7389.075	50 Year	477.64	678.70	695.39		695.39	0.000000	0.08	5907.98	461.99	0.00
Channel	7389.075	100 Year	464.90	678.70	697.09		697.09	0.000000	0.07	6697.81	466.88	0.00
Channel	7389.075	500 Year	3851.44	678.70	701.18		701.18	0.000003	0.46	8630.63	478.60	0.02
Channel	7389.075	5th Percentile	18.75	678.70	686.81		686.81	0.000000	0.01	2051.56	436.33	0.00
Channel	7389.075	Median Flow	79.76	678.70	686.44		686.44	0.000000	0.04	1893.32	434.99	0.00
Channel	5532.148	2 Year	301.13	679.90	687.34	681.16	687.34	0.000012	0.37	824.44	269.95	0.03
Channel	5532.148	5 Year	460.45	679.90	688.63	681.47	688.63	0.000011	0.41	1453.72	554.90	0.03
Channel	5532.148	10 Year	510.01	679.90	690.69	681.55	690.69	0.000004	0.29	2611.27	568.52	0.02
Channel	5532.148	50 Year	477.64	679.90	695.39	681.50	695.39	0.000000	0.14	5361.05	601.86	0.01
Channel	5532.148	100 Year	464.90	679.90	697.09	681.48	697.09	0.000000	0.12	6394.73	613.53	0.01
Channel	5532.148	500 Year	3851.44	679.90	701.17	684.53	701.17	0.000007	0.69	8951.54	639.65	0.03
Channel	5532.148	5th Percentile	18.75	679.90	686.81	680.23	686.81	0.000000	0.03	735.08	166.95	0.00
Channel	5532.148	Median Flow	79.76	679.90	686.44	680.55	686.44	0.000002	0.12	674.55	165.43	0.01
Channel	3522.239	2 Year	301.13	679.20	687.32		687.32	0.000010	0.32	1178.52	708.22	0.03
Channel	3522.239	5 Year	460.45	679.20	688.61		688.61	0.000007	0.32	2170.82	771.70	0.02
Channel	3522.239	10 Year	510.01	679.20	690.68		690.69	0.000002	0.21	3775.97	776.31	0.01
Channel	3522.239	50 Year	477.64	679.20	695.39		695.39	0.000000	0.10	7458.06	790.38	0.00
Channel	3522.239	100 Year	464.90	679.20	697.09		697.09	0.000000	0.08	8806.10	794.63	0.00
Channel	3522.239	500 Year	3851.44	679.20	701.16		701.16	0.000003	0.47	12063.38	804.83	0.02
Channel	3522.239	5th Percentile	18.75	679.20	686.81		686.81	0.000000	0.02	883.01	362.47	0.00
Channel	3522.239	Median Flow	79.76	679.20	686.44		686.44	0.000001	0.12	778.55	275.60	0.01
Channel	1410.166	2 Year	301.13	683.30	687.30		687.30	0.000008	0.20	1269.39	523.96	0.02
Channel	1410.166	5 Year	460.45	683.30	688.60		688.60	0.000006	0.23	2132.49	701.31	0.02
Channel	1410.166	10 Year	510.01	683.30	690.68		690.68	0.000002	0.17	3598.42	706.03	0.01
Channel	1410.166	50 Year	477.64	683.30	695.39		695.39	0.000000	0.09	6942.93	715.55	0.00
Channel	1410.166	100 Year	464.90	683.30	697.09		697.09	0.000000	0.07	8163.12	718.93	0.00
Channel	1410.166	500 Year	3851.44	683.30	701.15		701.16	0.000003	0.45	11103.55	727.55	0.02
Channel	1410.166	5th Percentile	18.75	683.30	686.81		686.81	0.000000	0.01	1048.85	370.29	0.00

HEC-RAS Plan: culvert_small River: Grey Cloud Reach: Channel (Continued)

Reach	River Sta	Profile	Q Total (cfs)	Min Ch El (ft)	W.S. Elev (ft)	Crit W.S. (ft)	E.G. Elev (ft)	E.G. Slope (ft/ft)	Vel Chnl (ft/s)	Flow Area (sq ft)	Top Width (ft)	Froude # Chl
Channel	1410.166	Median Flow	79.76	683.30	686.44		686.44	0.000001	0.07	919.24	337.01	0.01
Channel	415.9752	2 Year	301.13	680.80	687.29		687.29	0.000002	0.14	2243.38	557.03	0.01
Channel	415.9752	5 Year	460.45	680.80	688.60		688.60	0.000002	0.16	3163.34	874.25	0.01
Channel	415.9752	10 Year	510.01	680.80	690.68		690.68	0.000001	0.12	4995.71	883.01	0.01
Channel	415.9752	50 Year	477.64	680.80	695.39		695.39	0.000000	0.06	9224.47	933.21	0.00
Channel	415.9752	100 Year	464.90	680.80	697.09		697.09	0.000000	0.05	10849.03	966.97	0.00
Channel	415.9752	500 Year	3851.44	680.80	701.15		701.15	0.000002	0.33	14841.83	997.71	0.01
Channel	415.9752	5th Percentile	18.75	680.80	686.81		686.81	0.000000	0.01	1974.64	542.51	0.00
Channel	415.9752	Median Flow	79.76	680.80	686.43		686.43	0.000000	0.05	1775.72	531.52	0.00

HEC-RAS Plan: culvert River: Grey Cloud Reach: Channel

Reach	River Sta	Profile	Q Total (cfs)	Min Ch El (ft)	W.S. Elev (ft)	Crit W.S. (ft)	E.G. Elev (ft)	E.G. Slope (ft/ft)	Vel Chnl (ft/s)	Flow Area (sq ft)	Top Width (ft)	Froude # Chl
Channel	15516.50	2 Year	948.52	681.84	689.52		689.53	0.000054	0.79	1203.73	247.27	0.06
Channel	15516.50	5 Year	1520.74	681.84	692.13		692.14	0.000034	0.82	1869.89	265.00	0.05
Channel	15516.50	10 Year	1916.87	681.84	694.21		694.22	0.000024	0.81	2453.36	308.05	0.05
Channel	15516.50	50 Year	2613.75	681.84	698.47		698.47	0.000012	0.73	4429.38	551.59	0.03
Channel	15516.50	100 Year	2665.49	681.84	700.00		700.01	0.000008	0.65	5278.92	555.10	0.03
Channel	15516.50	500 Year	5555.94	681.84	703.56		703.58	0.000015	1.02	7270.74	564.15	0.04
Channel	15516.50	5th Percentile	48.19	681.84	686.82		686.82	0.000002	0.09	552.68	232.89	0.01
Channel	15516.50	Median Flow	229.92	681.84	686.70		686.70	0.000047	0.44	524.84	232.24	0.05
Channel	15462.15	2 Year	948.52	684.38	689.50		689.52	0.000149	1.16	822.85	204.10	0.10
Channel	15462.15	5 Year	1520.74	684.38	692.12		692.14	0.000073	1.13	1366.47	211.29	0.08
Channel	15462.15	10 Year	1916.87	684.38	694.20		694.21	0.000047	1.08	1815.16	227.31	0.06
Channel	15462.15	50 Year	2613.75	684.38	698.46		698.47	0.000021	0.94	3482.85	522.14	0.05
Channel	15462.15	100 Year	2665.49	684.38	700.00		700.01	0.000014	0.82	4287.44	524.62	0.04
Channel	15462.15	500 Year	5555.94	684.38	703.55		703.57	0.000025	1.27	6166.25	532.16	0.05
Channel	15462.15	5th Percentile	48.19	684.38	686.81		686.82	0.000010	0.16	296.37	177.97	0.02
Channel	15462.15	Median Flow	229.92	684.38	686.68		686.69	0.000288	0.84	272.82	175.53	0.12
Channel	15403.78	2 Year	948.52	683.69	689.48		689.51	0.000161	1.34	713.03	151.61	0.11
Channel	15403.78	5 Year	1520.74	683.69	692.10		692.13	0.000097	1.38	1122.12	161.16	0.09
Channel	15403.78	10 Year	1916.87	683.69	694.18		694.21	0.000067	1.35	1467.73	181.84	0.08
Channel	15403.78	50 Year	2613.75	683.69	698.45		698.47	0.000031	1.18	3024.07	473.43	0.06
Channel	15403.78	100 Year	2665.49	683.69	699.99		700.01	0.000020	1.02	3764.20	485.50	0.05
Channel	15403.78	500 Year	5555.94	683.69	703.54		703.57	0.000035	1.55	5514.23	502.17	0.06
Channel	15403.78	5th Percentile	48.19	683.69	686.81		686.81	0.000006	0.15	319.40	144.01	0.02
Channel	15403.78	Median Flow	229.92	683.69	686.67		686.68	0.000163	0.77	298.72	143.26	0.09
Channel	14983.37	2 Year	948.52	681.30	689.45		689.47	0.000056	0.98	1057.86	236.50	0.07
Channel	14983.37	5 Year	1520.74	681.30	692.08		692.10	0.000042	1.06	1855.33	368.87	0.06
Channel	14983.37	10 Year	1916.87	681.30	694.17		694.19	0.000030	1.02	2664.05	412.94	0.05
Channel	14983.37	50 Year	2613.75	681.30	698.45		698.46	0.000015	0.88	4611.12	478.38	0.04
Channel	14983.37	100 Year	2665.49	681.30	699.99		700.00	0.000010	0.78	5351.58	482.97	0.03
Channel	14983.37	500 Year	5555.94	681.30	703.54		703.56	0.000020	1.25	7085.05	493.59	0.05
Channel	14983.37	5th Percentile	48.19	681.30	686.81		686.81	0.000001	0.08	576.18	134.78	0.01
Channel	14983.37	Median Flow	229.92	681.30	686.66		686.66	0.000019	0.41	555.14	133.92	0.04
Channel	14111.45	2 Year	948.52	674.60	689.45		689.46	0.000004	0.34	3015.18	496.17	0.02
Channel	14111.45	5 Year	1520.74	674.60	692.09		692.09	0.000004	0.41	4432.08	564.03	0.02
Channel	14111.45	10 Year	1916.87	674.60	694.17		694.18	0.000004	0.43	5670.28	624.64	0.02
Channel	14111.45	50 Year	2613.75	674.60	698.45		698.45	0.000003	0.42	8509.96	700.71	0.02
Channel	14111.45	100 Year	2665.49	674.60	699.99		699.99	0.000002	0.39	9607.36	724.73	0.02
Channel	14111.45	500 Year	5555.94	674.60	703.54		703.55	0.000005	0.66	12297.19	788.14	0.02
Channel	14111.45	5th Percentile	48.19	674.60	686.81		686.81	0.000000	0.02	2001.53	256.84	0.00
Channel	14111.45	Median Flow	229.92	674.60	686.66		686.66	0.000001	0.12	1961.56	253.98	0.01
Channel	14030.47	2 Year	948.52	676.20	689.45		689.46	0.000009	0.49	2038.32	304.29	0.03
Channel	14030.47	5 Year	1520.74	676.20	692.08		692.09	0.000009	0.59	3041.58	476.44	0.03
Channel	14030.47	10 Year	1916.87	676.20	694.17		694.18	0.000008	0.61	4170.63	604.59	0.03
Channel	14030.47	50 Year	2613.75	676.20	698.45		698.45	0.000005	0.56	7022.65	729.59	0.02
Channel	14030.47	100 Year	2665.49	676.20	699.99		699.99	0.000003	0.51	8170.73	759.68	0.02
Channel	14030.47	500 Year	5555.94	676.20	703.54		703.55	0.000007	0.83	11007.94	842.04	0.03
Channel	14030.47	5th Percentile	48.19	676.20	686.81		686.81	0.000000	0.03	1388.05	202.12	0.00
Channel	14030.47	Median Flow	229.92	676.20	686.66		686.66	0.000002	0.17	1356.43	201.02	0.01
Channel	13998.91	2 Year	948.52	676.80	689.30	680.56	689.44	0.000231	2.99	317.40	247.68	0.15
Channel	13998.91	5 Year	1520.74	676.80	691.82	681.84	692.06	0.000318	3.97	382.78	308.16	0.18
Channel	13998.91	10 Year	1916.87	676.80	693.85	682.62	694.15	0.000328	4.40	435.52	388.33	0.19
Channel	13998.91	50 Year	2613.75	676.80	698.06	683.88	698.42	0.000289	4.80	545.09	598.20	0.18
Channel	13998.91	100 Year	2665.49	676.80	699.64	683.98	699.96	0.000236	4.55	586.17	666.64	0.17
Channel	13998.91	500 Year	5555.94	676.80	703.53	688.35	703.55	0.000012	1.02	8694.99	755.93	0.04
Channel	13998.91	5th Percentile	48.19	676.80	686.81	677.57	686.81	0.000001	0.19	252.68	172.21	0.01
Channel	13998.91	Median Flow	229.92	676.80	686.64	678.43	686.66	0.000031	0.93	248.25	170.66	0.05
Channel	13915.22		Culvert									
Channel	13839.69	2 Year	948.52	679.00	687.94	682.73	688.22	0.000719	4.20	225.66	191.24	0.25
Channel	13839.69	5 Year	1520.74	679.00	689.23	684.01	689.76	0.001167	5.87	258.99	196.15	0.33
Channel	13839.69	10 Year	1916.87	679.00	690.95	684.80	691.57	0.001089	6.31	303.81	217.79	0.33
Channel	13839.69	50 Year	2613.75	679.00	695.42	686.07	696.02	0.000688	6.22	420.00	398.79	0.27
Channel	13839.69	100 Year	2665.49	679.00	697.03	686.15	697.55	0.000521	5.77	462.01	450.77	0.24
Channel	13839.69	500 Year	5555.94	679.00	701.35	690.49	701.38	0.000026	1.32	5965.64	619.73	0.05
Channel	13839.69	5th Percentile	48.19	679.00	686.81	679.73	686.81	0.000003	0.25	196.15	183.70	0.02
Channel	13839.69	Median Flow	229.92	679.00	686.52	680.61	686.55	0.000077	1.22	188.77	179.60	0.08
Channel	13775.91	2 Year	948.52	677.10	688.07		688.08	0.000031	0.74	1277.27	186.79	0.05
Channel	13775.91	5 Year	1520.74	677.10	689.48		689.49	0.000043	0.99	1549.17	199.62	0.06
Channel	13775.91	10 Year	1916.87	677.10	691.24		691.26	0.000036	1.02	1914.21	213.08	0.06
Channel	13775.91	50 Year	2613.75	677.10	695.71		695.72	0.000018	0.93	3394.86	440.55	0.04
Channel	13775.91	100 Year	2665.49	677.10	697.29		697.29	0.000012	0.82	4093.08	445.37	0.04
Channel	13775.91	500 Year	5555.94	677.10	701.35		701.38	0.000022	1.27	5931.30	459.91	0.05
Channel	13775.91	5th Percentile	48.19	677.10	686.81		686.81	0.000000	0.05	1049.03	174.85	0.00

HEC-RAS Plan: culvert River: Grey Cloud Reach: Channel (Continued)

Reach	River Sta	Profile	Q Total (cfs)	Min Ch El (ft)	W.S. Elev (ft)	Crit W.S. (ft)	E.G. Elev (ft)	E.G. Slope (ft/ft)	Vel Chnl (ft/s)	Flow Area (sq ft)	Top Width (ft)	Froude # Chl
Channel	13775.91	Median Flow	229.92	677.10	686.54		686.54	0.000004	0.23	1001.52	172.27	0.02
Channel	13087.15	2 Year	948.52	677.20	688.04		688.05	0.000053	0.96	986.27	143.17	0.06
Channel	13087.15	5 Year	1520.74	677.20	689.43		689.45	0.000074	1.28	1187.25	146.09	0.08
Channel	13087.15	10 Year	1916.87	677.20	691.20		691.22	0.000061	1.33	1450.39	151.42	0.07
Channel	13087.15	50 Year	2613.75	677.20	695.68		695.70	0.000031	1.22	2532.22	358.55	0.06
Channel	13087.15	100 Year	2665.49	677.20	697.26		697.28	0.000022	1.08	3152.16	416.26	0.05
Channel	13087.15	500 Year	5555.94	677.20	701.32		701.35	0.000036	1.63	4926.16	443.25	0.06
Channel	13087.15	5th Percentile	48.19	677.20	686.81		686.81	0.000000	0.06	814.79	136.11	0.00
Channel	13087.15	Median Flow	229.92	677.20	686.53		686.53	0.000006	0.30	777.24	134.48	0.02
Channel	11895.96	2 Year	948.52	678.10	687.96		687.98	0.000067	1.04	911.32	141.12	0.07
Channel	11895.96	5 Year	1520.74	678.10	689.32		689.35	0.000091	1.38	1105.29	143.61	0.09
Channel	11895.96	10 Year	1916.87	678.10	691.12		691.15	0.000071	1.40	1492.19	272.42	0.08
Channel	11895.96	50 Year	2613.75	678.10	695.65		695.67	0.000028	1.14	3165.27	391.83	0.05
Channel	11895.96	100 Year	2665.49	678.10	697.24		697.26	0.000019	1.00	3792.37	394.56	0.04
Channel	11895.96	500 Year	5555.94	678.10	701.28		701.31	0.000032	1.51	5400.11	401.46	0.06
Channel	11895.96	5th Percentile	48.19	678.10	686.81		686.81	0.000000	0.06	753.02	133.16	0.00
Channel	11895.96	Median Flow	229.92	678.10	686.52		686.52	0.000008	0.32	715.22	131.19	0.02
Channel	10838.82	2 Year	948.52	674.40	687.91	677.99	687.92	0.000041	0.93	1017.24	128.21	0.06
Channel	10838.82	5 Year	1520.74	674.40	689.25	678.97	689.27	0.000063	1.28	1192.74	290.93	0.07
Channel	10838.82	10 Year	1916.87	674.40	691.06	679.51	691.08	0.000048	1.25	2007.29	385.58	0.07
Channel	10838.82	50 Year	2613.75	674.40	695.63	680.34	695.64	0.000020	1.02	3800.96	400.03	0.05
Channel	10838.82	100 Year	2665.49	674.40	697.23	680.43	697.24	0.000014	0.91	4445.85	405.14	0.04
Channel	10838.82	500 Year	5555.94	674.40	701.26	682.87	701.28	0.000025	1.40	6103.98	417.98	0.05
Channel	10838.82	5th Percentile	48.19	674.40	686.81	675.23	686.81	0.000000	0.05	879.14	122.41	0.00
Channel	10838.82	Median Flow	229.92	674.40	686.52	676.16	686.52	0.000004	0.27	843.70	120.87	0.02
Channel	9688.304	2 Year	948.52	675.30	687.87	678.36	687.88	0.000032	0.84	1127.42	136.45	0.05
Channel	9688.304	5 Year	1520.74	675.30	689.19	679.11	689.21	0.000050	1.16	1309.09	312.04	0.07
Channel	9688.304	10 Year	1916.87	675.30	691.01	679.55	691.03	0.000039	1.15	2152.90	388.36	0.06
Channel	9688.304	50 Year	2613.75	675.30	695.61	680.24	695.62	0.000017	0.96	3957.30	397.38	0.04
Channel	9688.304	100 Year	2665.49	675.30	697.22	680.30	697.22	0.000012	0.85	4598.86	400.54	0.04
Channel	9688.304	500 Year	5555.94	675.30	701.23	682.35	701.25	0.000022	1.34	6223.63	408.43	0.05
Channel	9688.304	5th Percentile	48.19	675.30	686.81	676.14	686.81	0.000000	0.05	985.48	130.76	0.00
Channel	9688.304	Median Flow	229.92	675.30	686.51	676.90	686.51	0.000003	0.24	947.11	129.18	0.02
Channel	8258.395	2 Year	948.52	677.10	687.80		687.82	0.000063	1.11	854.15	113.21	0.07
Channel	8258.395	5 Year	1520.74	677.10	689.08		689.11	0.000094	1.50	1138.51	293.86	0.09
Channel	8258.395	10 Year	1916.87	677.10	690.93		690.96	0.000068	1.44	1859.44	440.32	0.08
Channel	8258.395	50 Year	2613.75	677.10	695.58		695.59	0.000023	1.08	3927.43	449.82	0.05
Channel	8258.395	100 Year	2665.49	677.10	697.19		697.20	0.000015	0.94	4658.02	453.10	0.04
Channel	8258.395	500 Year	5555.94	677.10	701.20		701.22	0.000027	1.43	6487.71	461.19	0.05
Channel	8258.395	5th Percentile	48.19	677.10	686.81		686.81	0.000000	0.06	744.20	108.55	0.00
Channel	8258.395	Median Flow	229.92	677.10	686.51		686.51	0.000006	0.32	711.65	107.14	0.02
Channel	7389.075	2 Year	948.52	678.70	687.79		687.79	0.000011	0.38	2484.01	439.97	0.03
Channel	7389.075	5 Year	1520.74	678.70	689.07		689.08	0.000014	0.50	3049.08	443.48	0.03
Channel	7389.075	10 Year	1916.87	678.70	690.93		690.93	0.000010	0.50	3878.36	448.71	0.03
Channel	7389.075	50 Year	2613.75	678.70	695.58		695.58	0.000004	0.44	5995.39	462.54	0.02
Channel	7389.075	100 Year	2665.49	678.70	697.19		697.20	0.000003	0.40	6747.67	467.18	0.02
Channel	7389.075	500 Year	5555.94	678.70	701.20		701.20	0.000006	0.66	8640.62	478.66	0.03
Channel	7389.075	5th Percentile	48.19	678.70	686.81		686.81	0.000000	0.02	2052.49	436.34	0.00
Channel	7389.075	Median Flow	229.92	678.70	686.50		686.50	0.000001	0.12	1920.43	435.22	0.01
Channel	5532.148	2 Year	948.52	679.90	687.73	682.17	687.75	0.000092	1.06	891.51	417.27	0.08
Channel	5532.148	5 Year	1520.74	679.90	689.00	682.77	689.02	0.000095	1.25	1659.64	557.11	0.09
Channel	5532.148	10 Year	1916.87	679.90	690.88	683.13	690.90	0.000049	1.06	2722.45	569.97	0.06
Channel	5532.148	50 Year	2613.75	679.90	695.56	683.69	695.57	0.000014	0.76	5465.26	603.06	0.04
Channel	5532.148	100 Year	2665.49	679.90	697.18	683.73	697.19	0.000009	0.66	6453.55	614.18	0.03
Channel	5532.148	500 Year	5555.94	679.90	701.18	685.52	701.19	0.000015	1.00	8958.18	639.71	0.04
Channel	5532.148	5th Percentile	48.19	679.90	686.81	680.41	686.81	0.000000	0.07	735.39	166.96	0.01
Channel	5532.148	Median Flow	229.92	679.90	686.50	681.00	686.50	0.000012	0.34	683.78	165.67	0.03
Channel	3522.239	2 Year	948.52	679.20	687.57		687.58	0.000080	0.93	1368.41	765.74	0.08
Channel	3522.239	5 Year	1520.74	679.20	688.86		688.87	0.000064	0.97	2361.84	772.27	0.07
Channel	3522.239	10 Year	1916.87	679.20	690.83		690.83	0.000027	0.76	3884.82	776.57	0.05
Channel	3522.239	50 Year	2613.75	679.20	695.55		695.55	0.000007	0.52	7583.85	790.78	0.03
Channel	3522.239	100 Year	2665.49	679.20	697.17		697.18	0.000004	0.45	8875.47	794.85	0.02
Channel	3522.239	500 Year	5555.94	679.20	701.16		701.17	0.000007	0.68	12065.98	804.84	0.03
Channel	3522.239	5th Percentile	48.19	679.20	686.81		686.81	0.000000	0.06	883.43	364.88	0.01
Channel	3522.239	Median Flow	229.92	679.20	686.47		686.47	0.000012	0.33	788.08	276.55	0.03
Channel	1410.166	2 Year	948.52	683.30	687.41		687.42	0.000071	0.63	1330.23	558.42	0.07
Channel	1410.166	5 Year	1520.74	683.30	688.73		688.74	0.000060	0.73	2226.89	701.62	0.06
Channel	1410.166	10 Year	1916.87	683.30	690.77		690.78	0.000025	0.62	3663.41	706.24	0.04
Channel	1410.166	50 Year	2613.75	683.30	695.53		695.53	0.000007	0.47	7047.64	715.84	0.03
Channel	1410.166	100 Year	2665.49	683.30	697.17		697.17	0.000004	0.41	8219.90	719.08	0.02
Channel	1410.166	500 Year	5555.94	683.30	701.15		701.15	0.000007	0.65	11100.44	727.54	0.03
Channel	1410.166	5th Percentile	48.19	683.30	686.81		686.81	0.000000	0.04	1049.03	370.47	0.00

HEC-RAS Plan: culvert River: Grey Cloud Reach: Channel (Continued)

Reach	River Sta	Profile	Q Total (cfs)	Min Ch El (ft)	W.S. Elev (ft)	Crit W.S. (ft)	E.G. Elev (ft)	E.G. Slope (ft/ft)	Vel Chnl (ft/s)	Flow Area (sq ft)	Top Width (ft)	Froude # Chl
Channel	1410.166	Median Flow	229.92	683.30	686.45		686.45	0.000011	0.19	923.67	337.88	0.02
Channel	415.9752	2 Year	948.52	680.80	687.38		687.38	0.000018	0.42	2292.42	559.64	0.04
Channel	415.9752	5 Year	1520.74	680.80	688.70		688.71	0.000019	0.51	3259.10	874.75	0.04
Channel	415.9752	10 Year	1916.87	680.80	690.76		690.76	0.000009	0.44	5066.17	883.32	0.03
Channel	415.9752	50 Year	2613.75	680.80	695.53		695.53	0.000003	0.35	9357.81	936.33	0.02
Channel	415.9752	100 Year	2665.49	680.80	697.16		697.16	0.000002	0.31	10923.12	967.49	0.01
Channel	415.9752	500 Year	5555.94	680.80	701.15		701.15	0.000004	0.48	14835.50	997.66	0.02
Channel	415.9752	5th Percentile	48.19	680.80	686.81		686.81	0.000000	0.02	1974.87	542.53	0.00
Channel	415.9752	Median Flow	229.92	680.80	686.44		686.44	0.000002	0.13	1780.97	531.81	0.01

HEC-RAS Plan: bridge River: Grey Cloud Reach: Channel

Reach	River Sta	Profile	Q Total (cfs)	Min Ch El (ft)	W.S. Elev (ft)	Crit W.S. (ft)	E.G. Elev (ft)	E.G. Slope (ft/ft)	Vel Chnl (ft/s)	Flow Area (sq ft)	Top Width (ft)	Froude # Chl
Channel	15516.50	2 Year	1608.33	681.84	689.43		689.46	0.000165	1.36	1182.48	246.77	0.11
Channel	15516.50	5 Year	3261.22	681.84	691.97		692.02	0.000166	1.81	1826.74	263.47	0.12
Channel	15516.50	10 Year	4701.21	681.84	693.99		694.06	0.000153	2.04	2388.57	292.61	0.12
Channel	15516.50	50 Year	7777.78	681.84	698.20		698.27	0.000111	2.22	4283.55	550.99	0.11
Channel	15516.50	100 Year	9204.06	681.84	699.71		699.79	0.000102	2.29	5117.74	554.43	0.10
Channel	15516.50	500 Year	11238.32	681.84	703.39		703.45	0.000064	2.10	7176.25	563.71	0.09
Channel	15516.50	5th Percentile	69.92	681.84	686.82		686.82	0.000004	0.13	552.98	232.90	0.01
Channel	15516.50	Median Flow	303.74	681.84	686.69		686.70	0.000082	0.58	524.50	232.23	0.07
Channel	15462.15	2 Year	1608.33	684.38	689.38		689.44	0.000473	2.02	798.07	203.76	0.18
Channel	15462.15	5 Year	3261.22	684.38	691.90		692.00	0.000376	2.50	1321.26	210.61	0.17
Channel	15462.15	10 Year	4701.21	684.38	693.93		694.04	0.000315	2.74	1754.67	218.03	0.17
Channel	15462.15	50 Year	7777.78	684.38	698.14		698.26	0.000207	2.90	3314.16	521.61	0.14
Channel	15462.15	100 Year	9204.06	684.38	699.65		699.77	0.000183	2.94	4105.82	524.07	0.14
Channel	15462.15	500 Year	11238.32	684.38	703.36		703.45	0.000106	2.61	6061.96	531.74	0.11
Channel	15462.15	5th Percentile	69.92	684.38	686.82		686.82	0.000021	0.24	296.51	177.98	0.03
Channel	15462.15	Median Flow	303.74	684.38	686.67		686.69	0.000515	1.12	270.66	175.31	0.16
Channel	15403.78	2 Year	1608.33	683.69	689.32		689.41	0.000518	2.34	689.18	151.10	0.19
Channel	15403.78	5 Year	3261.22	683.69	691.82		691.97	0.000507	3.08	1077.28	160.07	0.20
Channel	15403.78	10 Year	4701.21	683.69	693.83		694.01	0.000458	3.45	1406.39	167.84	0.20
Channel	15403.78	50 Year	7777.78	683.69	698.05		698.24	0.000311	3.66	2833.22	470.69	0.18
Channel	15403.78	100 Year	9204.06	683.69	699.57		699.76	0.000273	3.69	3559.62	483.10	0.17
Channel	15403.78	500 Year	11238.32	683.69	703.31		703.44	0.000153	3.20	5397.14	500.68	0.13
Channel	15403.78	5th Percentile	69.92	683.69	686.81		686.82	0.000012	0.22	319.46	144.01	0.03
Channel	15403.78	Median Flow	303.74	683.69	686.65		686.67	0.000293	1.03	295.69	143.14	0.13
Channel	14983.37	2 Year	1608.33	681.30	689.23		689.28	0.000183	1.73	1005.77	231.12	0.12
Channel	14983.37	5 Year	3261.22	681.30	691.73		691.81	0.000225	2.39	1730.47	344.38	0.14
Channel	14983.37	10 Year	4701.21	681.30	693.77		693.86	0.000206	2.62	2500.81	396.94	0.14
Channel	14983.37	50 Year	7777.78	681.30	698.04		698.13	0.000145	2.73	4413.15	477.18	0.12
Channel	14983.37	100 Year	9204.06	681.30	699.56		699.65	0.000135	2.81	5143.92	481.69	0.12
Channel	14983.37	500 Year	11238.32	681.30	703.30		703.38	0.000087	2.58	6967.49	492.87	0.10
Channel	14983.37	5th Percentile	69.92	681.30	686.81		686.81	0.000002	0.12	576.15	134.78	0.01
Channel	14983.37	Median Flow	303.74	681.30	686.63		686.63	0.000034	0.55	550.93	133.75	0.05
Channel	14111.45	2 Year	1608.33	674.60	689.23		689.24	0.000013	0.60	2905.21	491.08	0.03
Channel	14111.45	5 Year	3261.22	674.60	691.74		691.75	0.000022	0.92	4235.73	558.49	0.05
Channel	14111.45	10 Year	4701.21	674.60	693.77		693.79	0.000026	1.09	5422.75	609.05	0.05
Channel	14111.45	50 Year	7777.78	674.60	698.04		698.06	0.000025	1.29	8222.41	694.93	0.05
Channel	14111.45	100 Year	9204.06	674.60	699.56		699.59	0.000026	1.38	9298.11	717.64	0.05
Channel	14111.45	500 Year	11238.32	674.60	703.30		703.33	0.000020	1.35	12111.04	784.36	0.05
Channel	14111.45	5th Percentile	69.92	674.60	686.81		686.81	0.000000	0.03	2001.49	256.84	0.00
Channel	14111.45	Median Flow	303.74	674.60	686.63		686.63	0.000001	0.16	1953.57	253.41	0.01
Channel	14030.47	2 Year	1608.33	676.20	689.22		689.23	0.000028	0.85	1969.80	297.10	0.05
Channel	14030.47	5 Year	3261.22	676.20	691.72		691.74	0.000048	1.31	2871.65	456.33	0.07
Channel	14030.47	10 Year	4701.21	676.20	693.75		693.79	0.000054	1.55	3923.67	572.64	0.07
Channel	14030.47	50 Year	7777.78	676.20	698.02		698.06	0.000047	1.73	6710.37	720.50	0.07
Channel	14030.47	100 Year	9204.06	676.20	699.54		699.58	0.000046	1.81	7832.60	751.30	0.07
Channel	14030.47	500 Year	11238.32	676.20	703.29		703.32	0.000032	1.70	10800.41	835.84	0.06
Channel	14030.47	5th Percentile	69.92	676.20	686.81		686.81	0.000000	0.05	1388.00	202.11	0.00
Channel	14030.47	Median Flow	303.74	676.20	686.63		686.63	0.000003	0.22	1350.06	200.76	0.02
Channel	13998.91	2 Year	1608.33	676.80	689.20	680.42	689.23	0.000064	1.41	1143.20	246.80	0.08
Channel	13998.91	5 Year	3261.22	676.80	691.65	681.78	691.74	0.000129	2.31	1412.95	295.21	0.11
Channel	13998.91	10 Year	4701.21	676.80	693.65	682.66	693.77	0.000166	2.88	1632.07	382.91	0.13
Channel	13998.91	50 Year	7777.78	676.80	697.82	684.19	698.04	0.000199	3.72	2091.52	566.36	0.15
Channel	13998.91	100 Year	9204.06	676.80	699.30	684.82	699.56	0.000217	4.08	2254.09	657.51	0.16
Channel	13998.91	500 Year	11238.32	676.80	703.27	685.69	703.32	0.000053	2.11	8494.70	749.51	0.08
Channel	13998.91	5th Percentile	69.92	676.80	686.81	677.71	686.81	0.000000	0.08	880.60	172.21	0.00
Channel	13998.91	Median Flow	303.74	676.80	686.62	678.45	686.63	0.000006	0.35	859.74	170.48	0.02
Channel	13915.22		Bridge									
Channel	13839.69	2 Year	1608.33	679.00	688.97	682.52	689.02	0.000171	1.89	850.00	195.19	0.12
Channel	13839.69	5 Year	3261.22	679.00	691.14	683.82	691.28	0.000310	3.00	1088.78	221.03	0.17
Channel	13839.69	10 Year	4701.21	679.00	692.97	684.77	693.18	0.000366	3.65	1290.60	276.65	0.19
Channel	13839.69	50 Year	7777.78	679.00	697.09	686.47	697.40	0.000369	4.47	1743.01	450.93	0.20
Channel	13839.69	100 Year	9204.06	679.00	698.52	687.18	698.89	0.000387	4.85	1901.07	534.16	0.21
Channel	13839.69	500 Year	11238.32	679.00	702.04	688.09	702.13	0.000092	2.55	6402.37	702.37	0.10
Channel	13839.69	5th Percentile	69.92	679.00	686.81	679.82	686.81	0.000001	0.11	616.28	183.73	0.01
Channel	13839.69	Median Flow	303.74	679.00	686.60	680.60	686.61	0.000019	0.51	594.42	181.00	0.04
Channel	13775.91	2 Year	1608.33	677.10	688.98		689.00	0.000059	1.11	1450.76	195.20	0.07
Channel	13775.91	5 Year	3261.22	677.10	691.17		691.22	0.000106	1.75	1899.15	212.63	0.10
Channel	13775.91	10 Year	4701.21	677.10	693.03		693.10	0.000123	2.12	2350.83	286.71	0.11
Channel	13775.91	50 Year	7777.78	677.10	697.19		697.27	0.000108	2.43	4049.11	445.09	0.11
Channel	13775.91	100 Year	9204.06	677.10	698.65		698.74	0.000107	2.55	4702.51	449.33	0.11
Channel	13775.91	500 Year	11238.32	677.10	702.04		702.12	0.000078	2.46	6248.58	463.30	0.09
Channel	13775.91	5th Percentile	69.92	677.10	686.81		686.81	0.000000	0.07	1049.69	174.89	0.00

HEC-RAS Plan: bridge River: Grey Cloud Reach: Channel (Continued)

Reach	River Sta	Profile	Q Total (cfs)	Min Ch El (ft)	W.S. Elev (ft)	Crit W.S. (ft)	E.G. Elev (ft)	E.G. Slope (ft/ft)	Vel Chnl (ft/s)	Flow Area (sq ft)	Top Width (ft)	Froude # Chl
Channel	13775.91	Median Flow	303.74	677.10	686.61		686.61	0.000006	0.30	1013.63	172.93	0.02
Channel	13087.15	2 Year	1608.33	677.20	688.91		688.94	0.000102	1.45	1112.04	144.98	0.09
Channel	13087.15	5 Year	3261.22	677.20	691.03		691.11	0.000188	2.30	1425.49	150.87	0.13
Channel	13087.15	10 Year	4701.21	677.20	692.85		692.97	0.000222	2.80	1711.18	169.05	0.14
Channel	13087.15	50 Year	7777.78	677.20	697.00		697.15	0.000198	3.24	3042.39	408.89	0.14
Channel	13087.15	100 Year	9204.06	677.20	698.46		698.62	0.000192	3.39	3666.50	437.83	0.14
Channel	13087.15	500 Year	11238.32	677.20	701.91		702.04	0.000131	3.15	5188.56	444.38	0.12
Channel	13087.15	5th Percentile	69.92	677.20	686.81		686.81	0.000001	0.09	815.28	136.13	0.01
Channel	13087.15	Median Flow	303.74	677.20	686.60		686.60	0.000011	0.39	786.32	134.87	0.03
Channel	11895.96	2 Year	1608.33	678.10	688.77		688.80	0.000130	1.57	1025.35	142.67	0.10
Channel	11895.96	5 Year	3261.22	678.10	690.77		690.86	0.000234	2.48	1399.98	260.50	0.14
Channel	11895.96	10 Year	4701.21	678.10	692.56		692.69	0.000253	2.90	1965.37	385.27	0.15
Channel	11895.96	50 Year	7777.78	678.10	696.80		696.92	0.000180	3.03	3616.46	393.79	0.14
Channel	11895.96	100 Year	9204.06	678.10	698.27		698.40	0.000172	3.15	4197.49	396.32	0.14
Channel	11895.96	500 Year	11238.32	678.10	701.78		701.89	0.000117	2.96	5599.51	402.35	0.12
Channel	11895.96	5th Percentile	69.92	678.10	686.81		686.81	0.000001	0.09	753.44	133.19	0.01
Channel	11895.96	Median Flow	303.74	678.10	686.58		686.59	0.000013	0.42	723.30	131.62	0.03
Channel	10838.82	2 Year	1608.33	674.40	688.66	679.10	688.69	0.000089	1.44	1114.33	279.37	0.09
Channel	10838.82	5 Year	3261.22	674.40	690.58	681.05	690.65	0.000167	2.27	1820.90	384.03	0.12
Channel	10838.82	10 Year	4701.21	674.40	692.37	682.26	692.46	0.000178	2.60	2513.03	389.72	0.13
Channel	10838.82	50 Year	7777.78	674.40	696.66	684.31	696.75	0.000136	2.77	4214.35	403.31	0.12
Channel	10838.82	100 Year	9204.06	674.40	698.13	685.01	698.23	0.000134	2.91	4813.10	408.02	0.12
Channel	10838.82	500 Year	11238.32	674.40	701.69	685.94	701.77	0.000095	2.77	6283.03	419.34	0.10
Channel	10838.82	5th Percentile	69.92	674.40	686.81	675.39	686.81	0.000000	0.08	879.50	122.42	0.01
Channel	10838.82	Median Flow	303.74	674.40	686.57	676.43	686.58	0.000007	0.36	850.67	121.18	0.02
Channel	9688.304	2 Year	1608.33	675.30	688.57	679.22	688.60	0.000070	1.31	1223.79	296.08	0.08
Channel	9688.304	5 Year	3261.22	675.30	690.41	680.77	690.47	0.000140	2.11	1917.76	387.17	0.11
Channel	9688.304	10 Year	4701.21	675.30	692.18	681.81	692.27	0.000154	2.44	2608.06	390.65	0.12
Channel	9688.304	50 Year	7777.78	675.30	696.52	683.60	696.60	0.000121	2.64	4319.01	399.16	0.11
Channel	9688.304	100 Year	9204.06	675.30	697.99	684.31	698.09	0.000119	2.77	4911.09	402.08	0.11
Channel	9688.304	500 Year	11238.32	675.30	701.59	685.21	701.67	0.000086	2.65	6368.29	409.13	0.10
Channel	9688.304	5th Percentile	69.92	675.30	686.81	676.26	686.81	0.000000	0.07	985.84	130.77	0.00
Channel	9688.304	Median Flow	303.74	675.30	686.57	677.12	686.57	0.000005	0.32	954.20	129.47	0.02
Channel	8258.395	2 Year	1608.33	677.10	688.41		688.46	0.000140	1.74	964.28	231.33	0.11
Channel	8258.395	5 Year	3261.22	677.10	690.07		690.19	0.000286	2.81	1482.76	438.42	0.16
Channel	8258.395	10 Year	4701.21	677.10	691.84		691.97	0.000278	3.09	2262.01	442.35	0.16
Channel	8258.395	50 Year	7777.78	677.10	696.30		696.40	0.000168	3.00	4252.09	451.28	0.13
Channel	8258.395	100 Year	9204.06	677.10	697.79		697.89	0.000159	3.08	4926.63	454.30	0.13
Channel	8258.395	500 Year	11238.32	677.10	701.45		701.53	0.000104	2.83	6604.94	461.71	0.11
Channel	8258.395	5th Percentile	69.92	677.10	686.81		686.81	0.000001	0.09	744.47	108.57	0.01
Channel	8258.395	Median Flow	303.74	677.10	686.56		686.56	0.000011	0.42	717.01	107.37	0.03
Channel	7389.075	2 Year	1608.33	678.70	688.40		688.41	0.000022	0.58	2752.63	441.77	0.04
Channel	7389.075	5 Year	3261.22	678.70	690.07		690.09	0.000041	0.93	3494.01	446.10	0.06
Channel	7389.075	10 Year	4701.21	678.70	691.84		691.86	0.000043	1.10	4289.21	451.52	0.06
Channel	7389.075	50 Year	7777.78	678.70	696.30		696.32	0.000033	1.24	6329.23	464.61	0.06
Channel	7389.075	100 Year	9204.06	678.70	697.79		697.81	0.000033	1.33	7024.62	468.88	0.06
Channel	7389.075	500 Year	11238.32	678.70	701.45		701.48	0.000024	1.31	8762.57	479.39	0.05
Channel	7389.075	5th Percentile	69.92	678.70	686.81		686.81	0.000000	0.03	2053.58	436.35	0.00
Channel	7389.075	Median Flow	303.74	678.70	686.55		686.55	0.000002	0.16	1941.79	435.40	0.01
Channel	5532.148	2 Year	1608.33	679.90	688.27	682.85	688.31	0.000191	1.63	985.85	532.09	0.12
Channel	5532.148	5 Year	3261.22	679.90	689.86	684.14	689.93	0.000252	2.21	2143.87	562.37	0.14
Channel	5532.148	10 Year	4701.21	679.90	691.65	685.05	691.71	0.000202	2.29	3159.33	575.65	0.13
Channel	5532.148	50 Year	7777.78	679.90	696.17	686.46	696.22	0.000101	2.12	5836.27	607.34	0.10
Channel	5532.148	100 Year	9204.06	679.90	697.67	686.96	697.72	0.000093	2.18	6751.88	617.46	0.10
Channel	5532.148	500 Year	11238.32	679.90	701.37	687.64	701.41	0.000058	1.99	9083.28	640.95	0.08
Channel	5532.148	5th Percentile	69.92	679.90	686.81	680.51	686.81	0.000001	0.10	735.77	166.97	0.01
Channel	5532.148	Median Flow	303.74	679.90	686.54	681.17	686.54	0.000021	0.44	691.03	165.85	0.04
Channel	3522.239	2 Year	1608.33	679.20	687.94		687.97	0.000160	1.37	1656.58	769.69	0.11
Channel	3522.239	5 Year	3261.22	679.20	689.49		689.52	0.000181	1.75	2845.91	773.73	0.12
Channel	3522.239	10 Year	4701.21	679.20	691.39		691.42	0.000118	1.67	4326.40	777.62	0.10
Channel	3522.239	50 Year	7777.78	679.20	696.07		696.09	0.000051	1.47	7996.82	792.09	0.07
Channel	3522.239	100 Year	9204.06	679.20	697.57		697.59	0.000046	1.50	9193.34	795.85	0.07
Channel	3522.239	500 Year	11238.32	679.20	701.32		701.34	0.000028	1.37	12190.83	805.23	0.06
Channel	3522.239	5th Percentile	69.92	679.20	686.81		686.81	0.000001	0.09	883.92	367.67	0.01
Channel	3522.239	Median Flow	303.74	679.20	686.50		686.50	0.000021	0.43	795.52	277.28	0.04
Channel	1410.166	2 Year	1608.33	683.30	687.59		687.61	0.000175	1.02	1437.22	619.18	0.10
Channel	1410.166	5 Year	3261.22	683.30	689.08		689.11	0.000210	1.46	2473.95	702.42	0.12
Channel	1410.166	10 Year	4701.21	683.30	691.15		691.17	0.000123	1.44	3930.22	707.09	0.10
Channel	1410.166	50 Year	7777.78	683.30	695.97		695.98	0.000052	1.34	7357.94	716.70	0.07
Channel	1410.166	100 Year	9204.06	683.30	697.48		697.50	0.000047	1.39	8446.87	719.71	0.07
Channel	1410.166	500 Year	11238.32	683.30	701.26		701.28	0.000029	1.30	11182.07	727.79	0.06
Channel	1410.166	5th Percentile	69.92	683.30	686.81		686.81	0.000001	0.05	1049.24	370.66	0.01

HEC-RAS Plan: bridge River: Grey Cloud Reach: Channel (Continued)

Reach	River Sta	Profile	Q Total (cfs)	Min Ch El (ft)	W.S. Elev (ft)	Crit W.S. (ft)	E.G. Elev (ft)	E.G. Slope (ft/ft)	Vel Chnl (ft/s)	Flow Area (sq ft)	Top Width (ft)	Froude # Chl
Channel	1410.166	Median Flow	303.74	683.30	686.46		686.46	0.000018	0.25	926.83	338.49	0.03
Channel	415.9752	2 Year	1608.33	680.80	687.52		687.53	0.000046	0.69	2370.21	563.75	0.06
Channel	415.9752	5 Year	3261.22	680.80	688.98		689.00	0.000072	1.03	3499.47	876.00	0.07
Channel	415.9752	10 Year	4701.21	680.80	691.08		691.10	0.000049	1.04	5352.25	884.75	0.06
Channel	415.9752	50 Year	7777.78	680.80	695.94		695.95	0.000024	0.99	9740.96	945.69	0.05
Channel	415.9752	100 Year	9204.06	680.80	697.45		697.47	0.000022	1.04	11204.84	969.44	0.05
Channel	415.9752	500 Year	11238.32	680.80	701.25		701.26	0.000014	0.97	14935.45	998.35	0.04
Channel	415.9752	5th Percentile	69.92	680.80	686.81		686.81	0.000000	0.04	1975.07	542.54	0.00
Channel	415.9752	Median Flow	303.74	680.80	686.45		686.45	0.000004	0.17	1784.51	532.01	0.02

DRAFT

Appendix D

DRAFT

Sediment Transport Results for the Small Culvert Alternative Using April through September Mean Monthly Discharges.

Small Culvert		April 1	Sept. 30	Difference (ft)	Sept. 30	Sept. 30
River Reach	Station	XS Invert Elev. (ft)	XS Invert El (ft)		XS Mass Bed Change (tons)	Cumulative Mass change (tons)
Grey Cloud	15516	681.84	682.60	0.76	207	207
Grey Cloud	15462	684.38	684.67	0.29	134	340
Grey Cloud	15403	683.69	683.71	0.02	30	371
Grey Cloud	14983	681.30	681.38	0.08	250	621
Grey Cloud	14111	674.60	674.62	0.02	92	713
Grey Cloud	14030	676.20	676.22	0.02	9	721
Grey Cloud	13998	676.80	676.82	0.02	2	724
Grey Cloud	13839	679.00	679.00	0.00	0	724
Grey Cloud	13775	677.10	677.11	0.01	20	744
Grey Cloud	13087	677.20	677.21	0.01	58	802
Grey Cloud	11895	678.10	678.11	0.01	36	837
Grey Cloud	10838	674.40	674.41	0.01	28	865
Grey Cloud	9688	675.30	675.30	0.00	29	894
Grey Cloud	8258	677.10	677.11	0.01	27	921
Grey Cloud	7389	678.70	678.70	0.00	51	971
Grey Cloud	5532	679.90	679.90	0.00	20	991
Grey Cloud	3522	679.20	679.20	0.00	13	1,005
Grey Cloud	1410	683.30	683.31	0.01	42	1,047
Grey Cloud	415	680.80	680.80	0.00	25	1,072
Total Incoming Sediment Load(tons): 3,329						

Sediment Transport Results for the Large Culvert Alternative Using April through September Mean Monthly Discharges.

Large Culvert		April 1	Sept. 30	Difference (ft)	Sept. 30	Sept. 30
River Reach	Station	XS Invert Elev. (ft)	XS Invert El (ft)		XS Mass Bed Change (tons)	Cumulative Mass change (tons)
Grey Cloud	15516	681.84	681.99	0.15	45	45
Grey Cloud	15462	684.38	683.51	-0.88	-451	-406
Grey Cloud	15403	683.69	683.69	0.00	7	-398
Grey Cloud	14983	681.30	681.48	0.18	769	370
Grey Cloud	14111	674.60	674.86	0.26	1,348	1,718
Grey Cloud	14030	676.20	676.29	0.09	34	1,752
Grey Cloud	13998	676.80	676.83	0.03	3	1,755
Grey Cloud	13839	679.00	678.68	-0.32	-71	1,684
Grey Cloud	13775	677.10	677.13	0.03	79	1,763
Grey Cloud	13087	677.20	677.21	0.01	57	1,820
Grey Cloud	11895	678.10	678.10	0.00	28	1,849
Grey Cloud	10838	674.40	674.41	0.01	50	1,898
Grey Cloud	9688	675.30	675.31	0.01	50	1,948
Grey Cloud	8258	677.10	677.11	0.01	53	2,001
Grey Cloud	7389	678.70	678.71	0.01	122	2,123
Grey Cloud	5532	679.90	679.90	0.00	10	2,133
Grey Cloud	3522	679.20	679.20	0.00	6	2,139
Grey Cloud	1410	683.30	683.31	0.01	78	2,217
Grey Cloud	415	680.80	680.81	0.01	111	2,328
Total Incoming Sediment Load(tons): 10,191						

DRAFT

Sediment Transport Results for the Bridge Alternative Using April through September Mean Monthly Discharges.

Bridge		April 1	Sept. 30	Difference (ft)	Sept. 30	Sept. 30
River Reach	Station	XS Invert Elev. (ft)	XS Invert El (ft)		XS Mass Bed Change (tons)	Cumulative Mass change (tons)
Grey Cloud	15516	681.84	680.90	-0.94	-300	-300
Grey Cloud	15462	684.38	682.25	-2.13	-1,117	-1,417
Grey Cloud	15403	683.69	681.81	-1.88	-3,088	-4,505
Grey Cloud	14983	681.30	681.66	0.36	1,407	-3,098
Grey Cloud	14111	674.60	675.45	0.85	4,836	1,738
Grey Cloud	14030	676.20	676.54	0.34	164	1,903
Grey Cloud	13998	676.80	673.26	-3.54	-1,620	283
Grey Cloud	13839	679.00	676.05	-2.95	-1,006	-723
Grey Cloud	13775	677.10	677.79	0.69	2,052	1,329
Grey Cloud	13087	677.20	677.37	0.17	946	2,275
Grey Cloud	11895	678.10	678.11	0.01	30	2,305
Grey Cloud	10838	674.40	674.50	0.10	559	2,864
Grey Cloud	9688	675.30	675.35	0.05	348	3,212
Grey Cloud	8258	677.10	677.12	0.02	79	3,291
Grey Cloud	7389	678.70	678.72	0.02	378	3,669
Grey Cloud	5532	679.90	679.85	-0.05	-786	2,883
Grey Cloud	3522	679.20	679.23	0.03	315	3,198
Grey Cloud	1410	683.30	683.46	0.16	1,363	4,561
Grey Cloud	415	680.80	680.86	0.06	589	5,150
Total Incoming Sediment Load(tons): 14,381						

Sediment Transport Results for the Bridge Alternative Assuming a 100 year Steady Discharge for a 30 day Period.

Bridge		April 1	April 30	Difference (ft)	April 30	April 30
River Reach	Station	XS Invert Elev. (ft)	XS Invert El (ft)		XS Mass Bed Change (tons)	Cumulative Mass change (tons)
Grey Cloud	15516	681.84	679.02	-2.82	-868	-868
Grey Cloud	15462	684.38	680.23	-4.16	-2,175	-3,042
Grey Cloud	15403	683.69	679.39	-4.30	-7,034	-10,077
Grey Cloud	14983	681.30	681.81	0.51	2,164	-7,913
Grey Cloud	14111	674.60	675.66	1.06	6,514	-1,399
Grey Cloud	14030	676.20	671.80	-4.40	-2,390	-3,789
Grey Cloud	13998	676.80	673.55	-3.25	-1,509	-5,298
Grey Cloud	13839	679.00	675.76	-3.24	-1,846	-7,144
Grey Cloud	13775	677.10	675.27	-1.83	-5,982	-13,126
Grey Cloud	13087	677.20	676.70	-0.50	-3,148	-16,274
Grey Cloud	11895	678.10	678.11	0.01	68	-16,207
Grey Cloud	10838	674.40	675.26	0.86	5,674	-10,533
Grey Cloud	9688	675.30	675.43	0.13	1,109	-9,424
Grey Cloud	8258	677.10	677.46	0.36	2,222	-7,203
Grey Cloud	7389	678.70	678.85	0.15	4,275	-2,928
Grey Cloud	5532	679.90	680.01	0.11	1,686	-1,242
Grey Cloud	3522	679.20	679.29	0.09	1,371	130
Grey Cloud	1410	683.30	683.46	0.16	1,639	1,768
Grey Cloud	415	680.80	680.85	0.05	561	2,330
Total Incoming Sediment Load(tons): 48,509						